

IR-Sensor Switch E18

This is Sensor Infrared device for distance detection that can be adjusted in the range of 6 cm.-80 cm.; and

Output is Logic TTL; 0 (GND) and 1 (5V).

Specifications

- Adjust distance detection in the range of 6 cm.-80 cm. by Adjustable VR and display the status by LED
- Sensing device should be opaque material or any material that allows less light to pass through; black color is the best because Sensor device works well by using reflection of Infrared
- OUTPUT is Open Collector; it has to connect R 10 K Pull Up at Out Putt
- Signal Output is Digital TTL; 0 = GND and 1 = 5V
- Use Power Supply DC 5V Current 100mA

How to setup distance detection: Before using, it has to setup preferable distance detection for using with Sensor as follows;

- 1) Provide 5V Power Supply (brown cable) and GND (blue cable) to Sensor
- 2) Turn the head of Sensor upright to the ground or wall (it is the best if ground or wall is black color)
- 3) Measure the preferable distance detection from ground or wall to the head of Sensor by ruler; and hold Sensor at the preferable position to detect for awhile
- 4) Adjust VR at the end of Sensor. Look at the change of LED at the end of Sensor as described below;

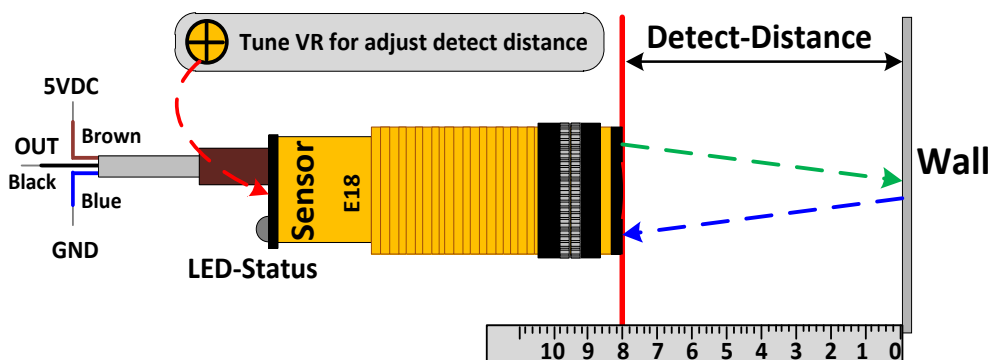

- If LED is OFF (OUTPUT = 1), please adjust VR in a clockwise direction until LED becomes ON (OUTPUT = 0) and then stop adjusting VR. The position that LED changes the state is the specified distance detection. This is conditional operation; *if the distance of Sensor is less than or equal to the distance detection*, LED Status is ON and OUTPUT becomes Logic 0; but if the distance of Sensor is greater than the distance detection, LED Status is OFF and OUTPUT becomes Logic 1 instead.

- If LED is ON (OUTPUT = 0), please adjust VR in an anticlockwise direction until LED becomes OFF (OUTPUT = 1) and then stop adjusting VR. The position that LED changes the state is the specified distance detection. This is conditional operation; *if the distance of Sensor is greater than or equal to the distance detection*, LED Status is OFF and OUTPUT becomes Logic 1; but if the distance of Sensor is less than the distance detection, LED Status is ON and OUTPUT becomes Logic 0 instead.

- 5) Test the operation of Sensor by moving Sensor. When the head of Sensor moves and passes the specified distance detection, LED of Sensor is lit up if the distance of Sensor is less or equal to the specified distance detection; but LED is OFF if the distance of Sensor is greater than or equal to the specified distance detection. If it does not accord with any conditional operation described above, it means that it fails to setup any distance detection for Sensor.

Referred to experiment in use, it found that color of ground or wall or any material that is used to reflect to Sensor is not enough dark. If the wall that is used to reflect is light color, the least distance detection of Sensor is also higher; so, the specified distance detection of user is lower than the least distance detection of Sensor. In this case, it should use wall with the dark color or it may setup the

distance detection higher, depend on material of user. User has to test and setup distance detection by self because each color of wall that reflects to Sensor is different; and finally, user needs to return to step 1-5. Referred to experiment, the least distance detection of the black wall that can reflect to Sensor is 6 cm; the operating result accords with step 5, it means that it succeeds and Sensor is ready to use and connect.

How to use Sensor after setup distance detection

Please look at the circuit below and connect Sensor with Connectors according to the specified color; Brown Cable is 5VDC Power Supply, Blue Cable is GND, and Black Cable is OUTPUT(TTL). Next, please look at the conditional operation of Sensor to write program correctly.

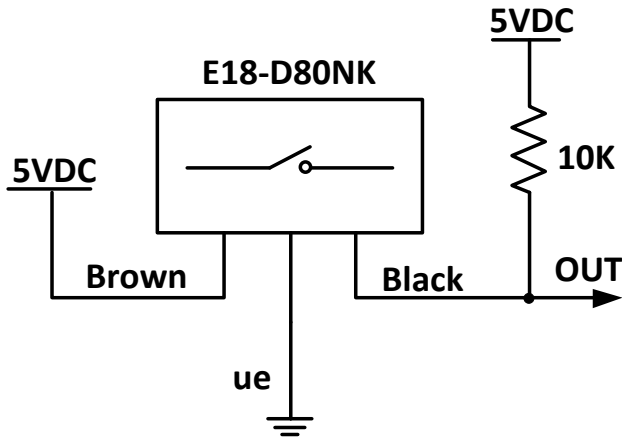

Connector and Circuit

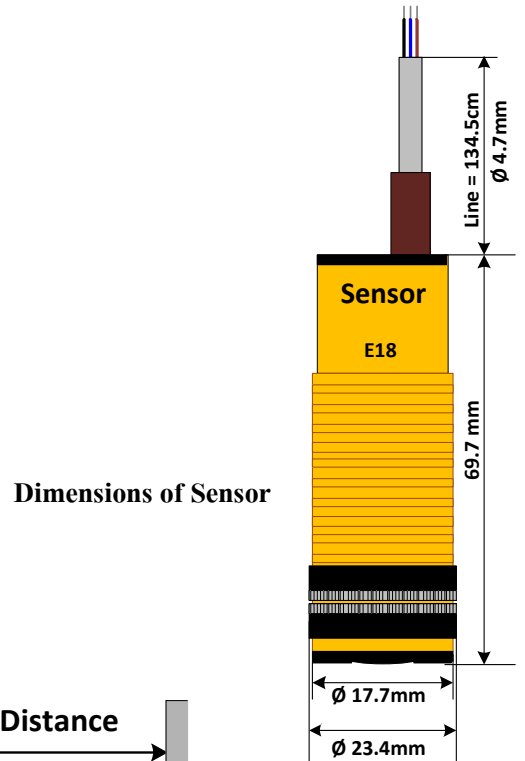

Dimensions of Sensor

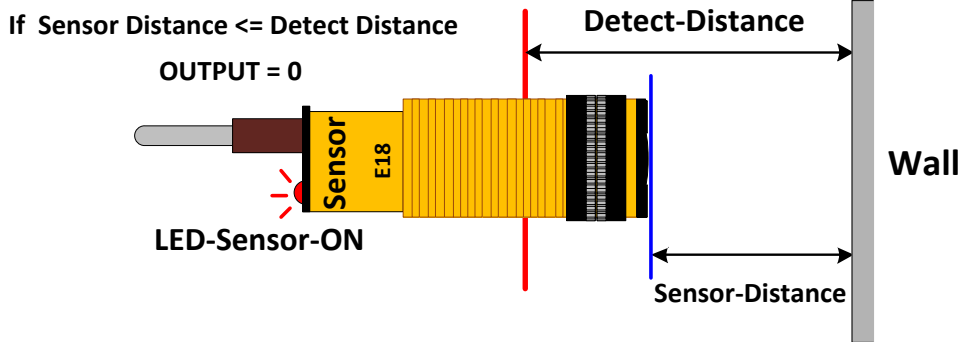

When distance of Sensor \leq the specified distance detection, LED Status is ON and OUTPUT = 0

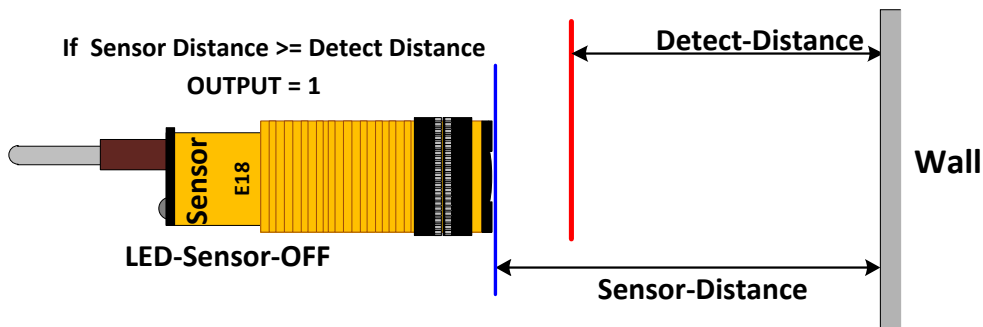

When distance of Sensor \geq the specified distance detection, LED Status is OFF and OUTPUT = 1