

ACLAVIS 7.0"

Master Data Sheet



Compliant with RoHS directive 2011/65/EU

Description:

LCD:	17.8 cm [7.0"] TFT Display
Resolution:	800 x 480 pixel
Cover Glass:	2 mm glass
Dimension:	193.5 x 132.5 mm (cover lens)
Max. Thickness:	14.5 mm (complete unit)

Available types (part numbers):

GETM0700G0EDH6GLYN01 = chemically strengthened, anti-glare

GETM0700G0EDH6GLYN02 = chemically strengthened, anti-reflective, anti-finger print

GETM0700G0EDH6GLYN03 = standard float glass, glossy

Table of Content:

Page 3-5	Your Benefits
Page 6	1.0. General Specification
Page 6-10	2.0. Inspection and Handling Standards
Page 10	3.0. Revision History

Appendix:

- Technical Drawings (cover glass and complete unit). The drawings show the dimensions of the Anti-Glare version **GETM0700G0EDH6GLYN01**, which is representative for all types.

Your Benefit

Cover Glass Design

- Corners are rounded (R4)
- Edges are smoothed and chamfered
- Double silk-screen printing for increased opacity (deep black RAL 9005)

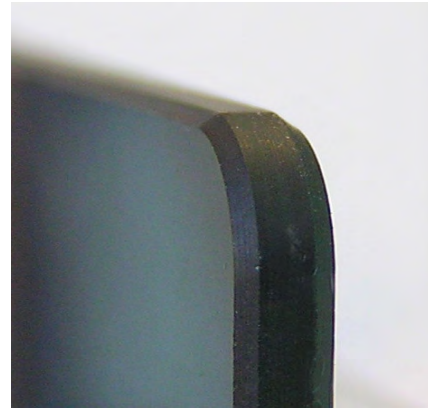

Surface Treatment (Anti-Glare, Anti-Reflection, Anti-Finger Print)

Anti-glare (etching) used for **GETM0700G0EDH6GLYN01**.

The smooth surface is ideal for touch application.

- Anti-smudge effect
- Easy to clean
- Pleasant feel for fingers
- Diffused light-reflection

Anti-Glare is no coating but an etching of the surface. Therefore, it is not susceptible to abrasion.

Anti-Reflection and Anti-Finger Print coating used for the **GETM0700G0BDH6GLYN02**.

In contrast to the anti-glare treatment this coating does NOT diffuse light but reduces reflections. An additional anti-finger print coating makes it robust and easy to clean. Regarding abrasion see Schott's technical data sheet (CONTURAN® DARO). **GETM0700G0BDH6GLYN03** has no surface treatment.

Chemically strengthened

- Up to 5 times higher bending and breaking strength

Used for **GETM0700G0EDH6GLYN01** and **GETM0700G0EDH6GLYN02**.

Optical Bonding

The cover lens and LCD unit optically bonded (full-faced).
This provides exceptionally high adhesion.

- No humidity or foreign particles can get in between
- Best possible touch sensor performance
- Reduction of light reflection
- Increased stability

True Multi-Touch

Thanks to EDT's PolyTouch technology, this product offers **simultaneous 5-finger** recognition.

The integrated controller offers a **standard I²C interface**. Sensitivity of the touch sensor can easily be changed via standard register addresses.

GLYN TFT Family Concept

This 7" LCD offers the **same interface** as our standard GLYN family 3.5", 4.3", 5.0" and 5.7" products (without cover glass). The main features of this family are:

- -20 to 70°C (operating)
- Integrated voltage generation for LED backlight and TFT driving
- 3.3V single power supply
- One connector (touch and backlight integrated)
- PWM dimming control (backlight brightness)

1.0. General Specification

Weight: ~400 g

Brightness: ca. 10% less compared to LCD without cover glass

Color Tolerance: $\Delta E \leq 1.0$ (this applies to the silk-screen print of the cover glass)

2.0. Inspection and Handling Standards

2.1. Bonding Glue

Due to the “Bonding” process slight amounts of glue may leak beyond the bonding area. Glue residue may be visible on the glass print up to 5 mm outside the touch sensor area.

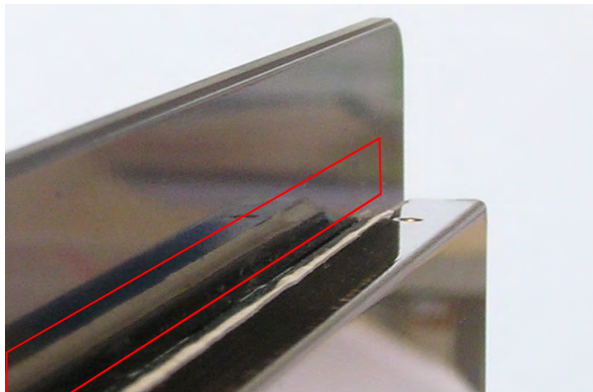

2.2. Use of Cleaning and Adhesive Products

The **front side** has no special coating (except for the anti-reflection version which needs to be handled with slightly more care). Therefore, it is **not** particularly sensitive to cleaning agents. Standard glass cleaning products may be used. In rare cases, de-ionised (demineralized) water in combination with high temperature can cause a reaction. This chemical reaction may cause stains to be visible on the surface.

The **rear side** is covered with a silk-screen print. This print is susceptible to mechanical impact and abrasion. Aggressive cleaning agents should **not** be used. For more information on the paint please take a look at the Technical Data (appendix of this document).

The usability of any glue or cleaning agent (front side, rear side) has to be tested and approved by the customer.

2.3. Cosmetic Quality Inspection Criteria

Our cosmetic quality inspection is aimed at insuring high quality. The following components are prone to contain potential defects:

- Display glass panel (surface)
- Display polarization film
- Air gap between polarizer and touch sensor
- Touch sensor bonding (inside touch sensor)
- Touch sensor glass (surface)
- Optical bonding between touch sensor and cover glass
- Cover glass (including printing)

Glass is a raw material which always contains micro-impurities. Most of them cannot be seen with the naked eye. The following specification defines the maximum allowed number and size of scratches, digs and foreign matter. Non-specified impurities/defects or a combination of a few minor ones in the cover glass need to be handled on an individual basis. For more information please contact our **QM department**.

2.3.1. Scratches (scratch-like impurities) and foreign material (e.g. long fibers)

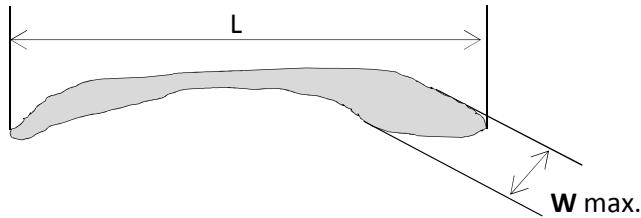

$$W = W \text{ max.}$$

Length: L (in mm)	Width: W (in mm)	Allowed number
$L \leq 0.3$	$W \leq 0.05$	Ignore
$0.3 < L \leq 2.5$	$0.05 < W \leq 0.1$	4
$2.5 < L \leq 4.0$	$0.05 < W \leq 0.1$	1
> 4.0	> 0.1	Not allowed
The total number must not exceed 4 (e.g. 1 x up to 4.0 mm plus 3 x up to 2.5 mm)		

2.3.2. Digs, bubbles, stains, dents, pinholes (in printing), foreign material (e.g. near round-shaped or rectangular-shaped particles)

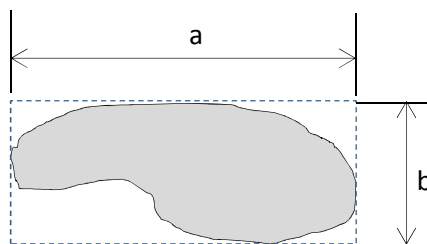

$$A = a * b$$

Area = (a*b) (in mm)	Allowed number
$A \leq 0.1$	Ignore
$0.1 < A \leq 0.36$	4
> 0.36	Not allowed



- a) Long defects (2.3.1.) and spots/digs (2.3.2.) are regarded as cumulative. 2 x long defects and 2 x spots/digs at the same time are acceptable.
- b) A concentration of defects is not allowed
- c) Removable stains or marks are not regarded as defects
- d) Edge chips: 5 x 0.4 mm (e.g. size = 0.4 x 0.4 mm) are acceptable
- e) Defects like clouds/stains (mura) exist in a great variety and are sometimes observed only under special conditions (light, angle, reflection etc.). Therefore, they are not specified because these effects have to be discussed and specified based on bad/good limit samples. Clearly visible clouds/stains (mura) which can immediately be seen under all conditions (see below specified time, distance and angle) are not allowed.

Condition of Inspection

Inspection in transmission, reflection, printed glasses, always from the viewer's side.

Inspection angle 45° to 90°

Inspection time: max. 10 sec.

Distance: 500 mm

Max. 1000 Lux in front of black background

Colour temperature: D65 (CIE standard)

2.4. Silk-screen print

The printing process is set up in a way that there is no paint overflow at the edge. Therefore, a safety distance has to be kept to the edge. This may lead to a small area without paint.

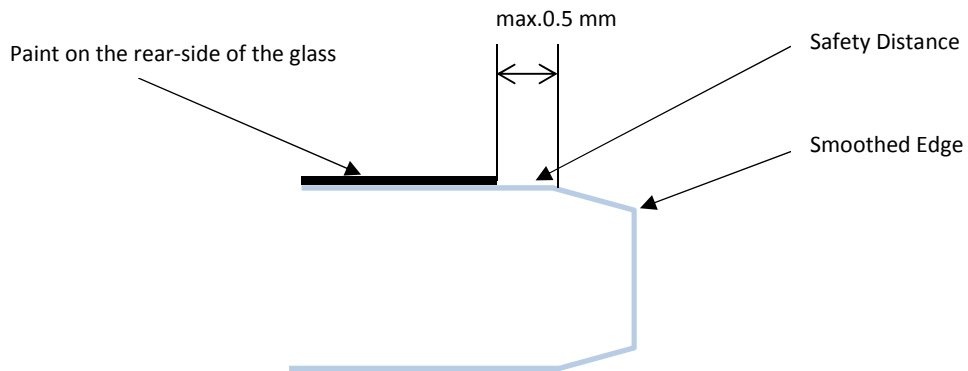

3.0. Revision History

Date	Version	Section	Remark
15.03.2016	1.0	-	First release
04.05.2016	1.1	-	Two versions added with AR coating (GLYN02) and without treatment (GLYN03).

The information contained herein is subject to change without prior notice. This master data sheet does not replace the original information of the LCD data sheet. For valid specification please refer to the original manufacturer's data sheet.

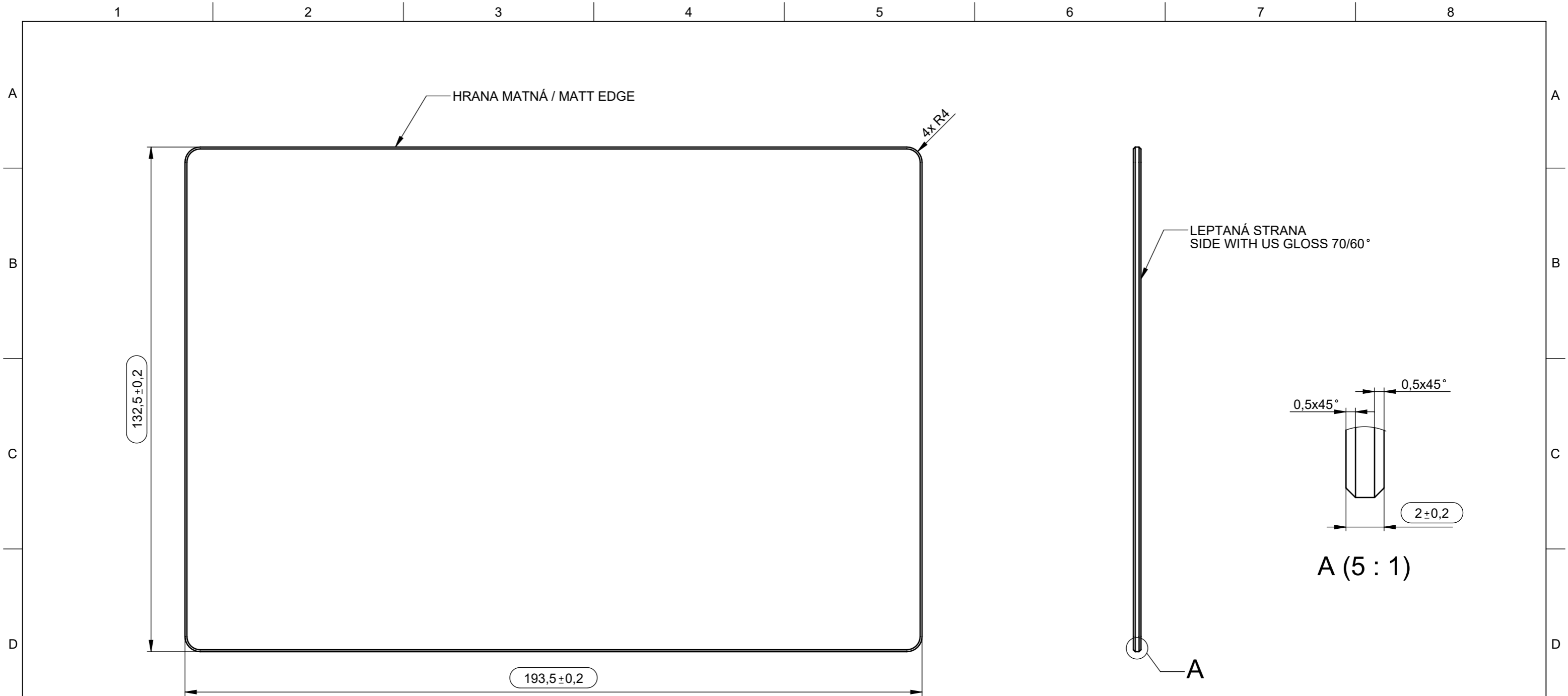

○ KONTROLNÍ ROZMĚR
KEY CHARACTERISTIC

04			
03			
02			
01			
Index	Popis / Description	Kreslil / Drawn by	Datum / Date

Tolerance : ISO 2768 - m K	Měřítko : Scale: 1:1	Tolerance: Tolerance: ISO 2768-mK	Materiál: 2 mm Weißglas Material: NFT Gloss 70	Povrchová úprava: chemicky zpevněno Surface treatment: chemically strenghtened
0 - 6 +/-0,1	Kreslil: P. Pohan	Datum: 4.12.2015	Podpis:	Název souboru: File name:
6 - 30 +/-0,2	AKI ELECTRONIC spol s r.o. Jihlava - CZ	Zákazník / Customer:		Číslo výkresu / Drawing No.:
30 - 120 +/-0,3		Název výkresu: SKLO 193,5x132,5x2		10051HT4691-01
120 - 400 +/-0,5		Drawing name: GLASS 193,5x132,5x2		1/1
400 - 1000 +/-0,8				Format: A3

Elektronický originál v IS Helios. Papírové kopie jsou neplatné pro výrobu, pokud nejsou označeny číslem kopie a datem.

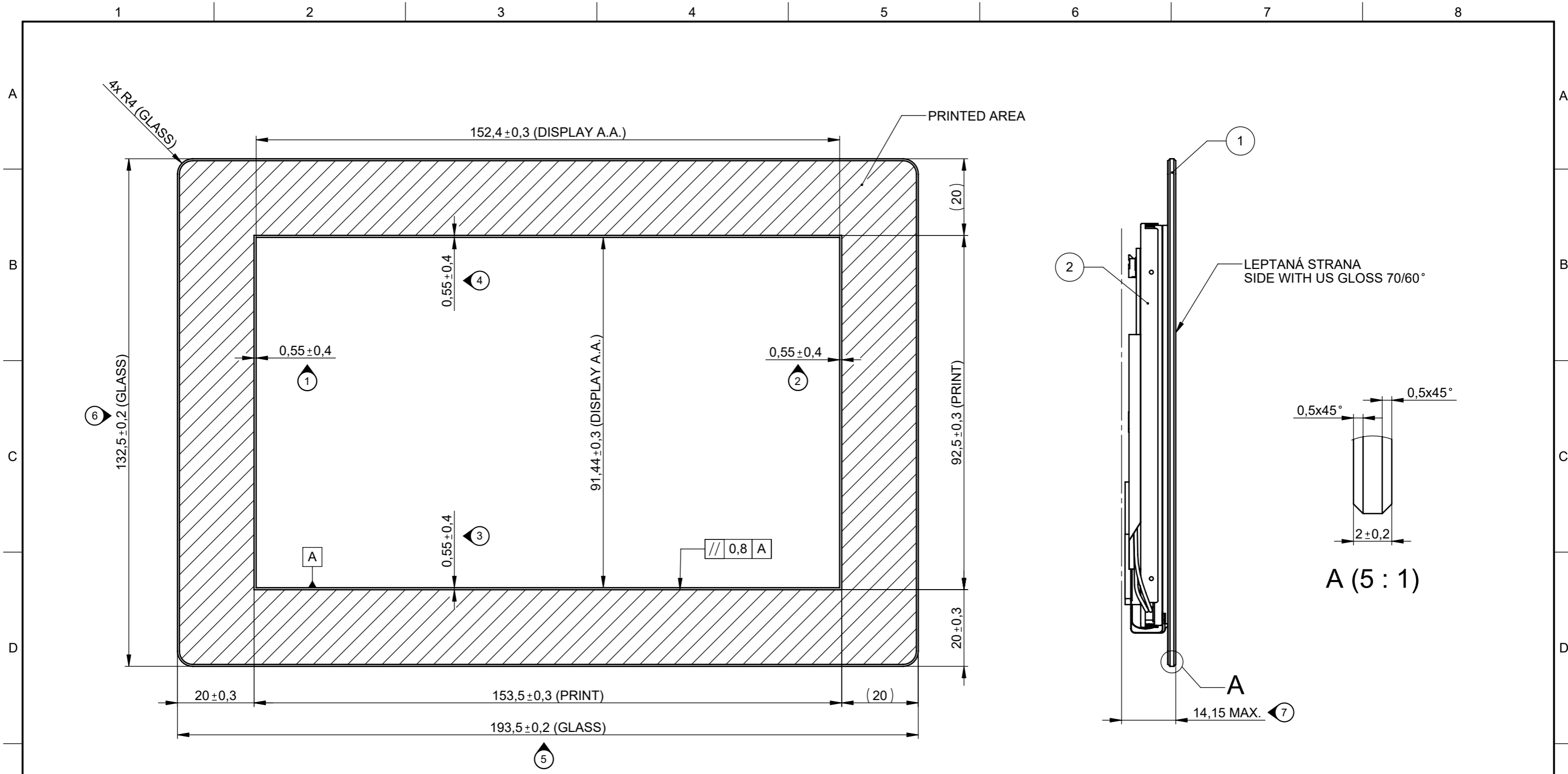

11	10	9	8	4	1	1	1	1
11	10	9	8	4	1	1	1	1
				Etiketa S/N	1	Etiketa S/N	1	Etikette 2
				Etiketa Artikelnummer	1	Etiketa Artikelnummer	1	Etikette 1
				Display G-ETM0700G0EDH6	1	Display G-ETM0700G0EDH6	1	1007374000292
				Sklo/Glass AG 193,5 x 132,5 x 2	1	Sklo/Glass AG 193,5 x 132,5 x 2	1	HT 4691-01-00; HT 4691-09-00
				Pozice	Množství	Popis		Poznámka
				Position	Quantity	Description		Notes

Tolerance : ISO 2768 - m	
0 - 6	+/-0,1
6 - 30	+/-0,2
30 - 120	+/-0,3
120 - 400	+/-0,5
400 - 1000	+/-0,8

VŠECHNY CHYBĚJÍCÍ ROZMĚRY V 3D SOUBORU. ALL MISSING DIMENSIONS ARE IN THE 3D DATA. KONTROLNÍ ROZMĚR KEY CHARACTERISTIC

INDEX	POPIS DESCRIPTION	DATUM DATE	JMÉNO NAME
MATERIÁL / MATERIAL:		VŠECHNY ROZMĚRY V MILIMETRECH (mm) / ALL DIMENSIONS IN MILLIMETERS (mm)	
POVRCH. ÚPRAVA / SURF. FINISH:		NÁZEV SOUBORU: FILE NAME:	
VYPRACOVAL / DRAWN: P. POHAN		TOLERANCE: ISO 2768 mK	FORMÁT: ORIGINAL SIZE: A3
TECHNOLOG / CHECKED:		DATUM / DATE: 22.2.2016	PROMÍTÁNÍ: PROJECTION:
AKI ELECTRONIC spol. s r.o. Znojemská 94 586 01 Jihlava Czech Republic		NÁZEV: TITEL: KONTROLNÍ PLÁN INSPECTION PLAN	MĚŘÍTKO: SCALE: 1:1
		ČÍSLO VÝKRESU: DRAWING NUMBER: HT 4808-00-00	LIST / LISTU: SHEET / SHEETS: 1/2

Elektronický originál v IS Helios. Papírové kopie jsou neplatné pro výrobu, pokud nejsou označeny číslem kopie a datem.

ZADNÍ STRANA / REAR VIEW

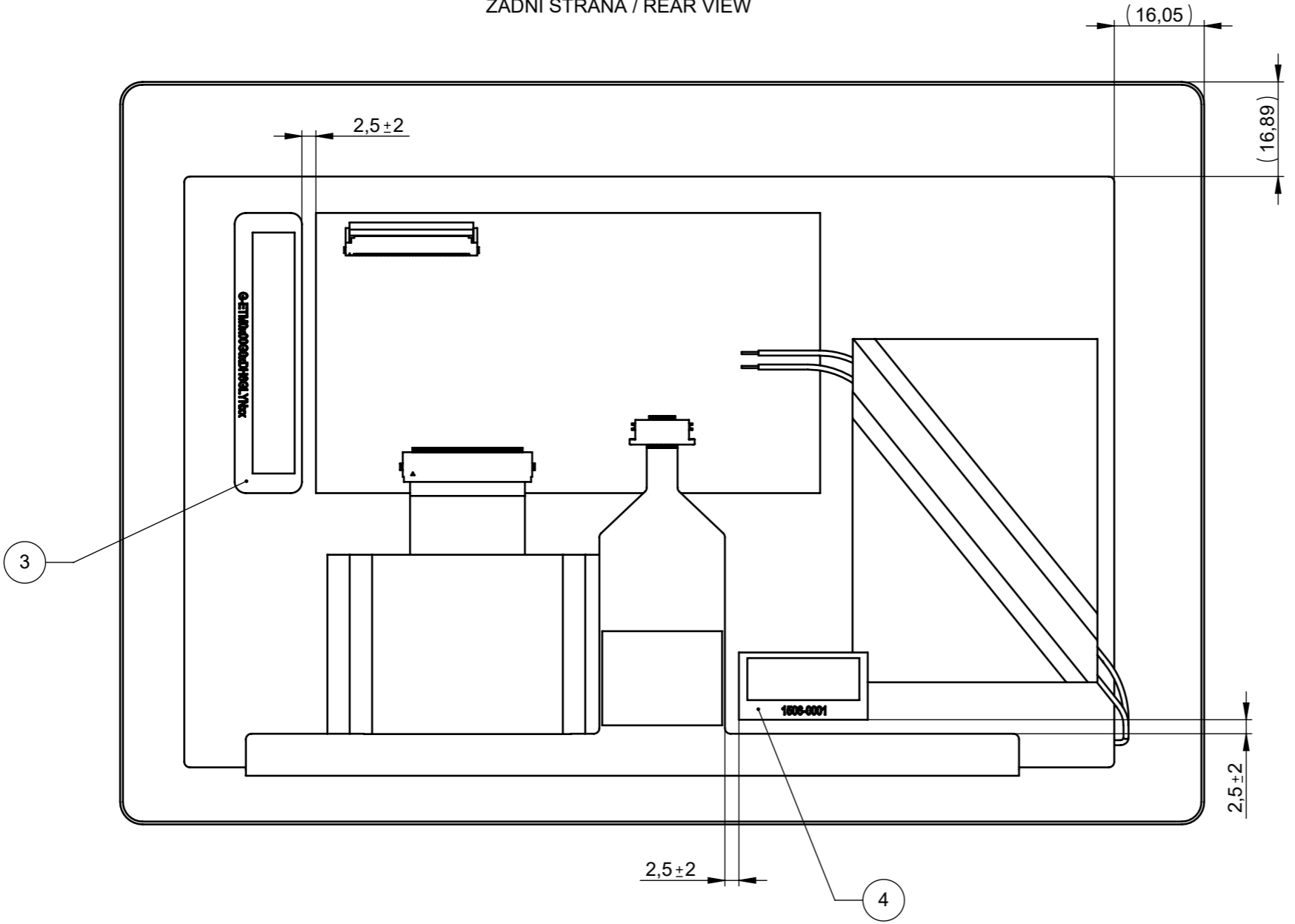

VŠECHNY CHYBĚJÍCÍ ROZMĚRY V 3D SOUBORU.
ALL MISSING DIMENSIONS ARE IN THE 3D DATA.

KONTROLNÍ ROZMĚR
KEY CHARACTERISTIC

Tolerance : ISO 2768 - m	
0 - 6	+/-0,1
6 - 30	+/-0,2
30 - 120	+/-0,3
120 - 400	+/-0,5
400 - 1000	+/-0,8

INDEX	POPIS DESCRIPTION	DATUM DATE	JMÉNO NAME
MATERIÁL / MATERIAL:		VŠECHNY ROZMĚRY V MILIMETRECH (mm) / ALL DIMENSIONS IN MILLIMETERS (mm)	
POVRCH. ÚPRAVA / SURF. FINISH:		NÁZEV SOUBORU: FILE NAME:	
VYPRACOVAL / DRAWN: P. POHAN	TOLERANCE: ISO 2768 mK	FORMÁT: ORIGINAL SIZE: A3	PROMÍTÁNÍ: PROJECTION:
TECHNOLOG / CHECKED:	DATUM / DATE: 22.2.2016	MĚŘÍTKO: SCALE: 1:1	
AKI ELECTRONIC spol. s r.o. Znojemská 94 586 01 Jihlava Czech Republic	NÁZEV: TITILE: KONTROLNÍ PLÁN INSPECTION PLAN	ČÍSLO VÝKRESU: DRAWING NUMBER: HT 4808-00-00	LIST / LISTU: SHEET / SHEETS: 2/2

Reprodukční, šíření a poskytnutí tohoto dokumentu, jeho částí nebo obsahu třetí osobě je bez výslovného souhlasu zakázáno. Porušení zákazu vede k odpovědnosti za vzniklou škodu. Všechna práva jsou vyhrazena rovněž v případech registrovaného patentu, průmyslového vzoru nebo výtvarného návrhu. / The reproduction, distribution and utilization of this document as well as the communication of its contents to others without express authorization is prohibited. Offenders will be held liable for the payment of damages. All rights reserved in the event of the grant of a patent, utility model or design.

Elektronický originál v IS Helios. Papírové kopie jsou neplatné pro výrobu, pokud nejsou označeny číslem kopie a datem.

1 2 3 4 5 6 7 8

A
B
C
D
E
F



RAL 9005
Transparent / Glas

Tolerance : ISO 2768 - m	
0 - 6	+/-0,1
6 - 30	+/-0,2
30 - 120	+/-0,3
120 - 400	+/-0,5
400 - 1000	+/-0,8

xx		xx		xx		xx	
INDEX	POPIŠ DESCRIPTION			DATUM DATE		JMÉNO NAME	
MATERIÁL / MATERIAL:		2 mm Weißglas NFT Gloss 70		VŠECHNY ROZMĚRY V MILIMETRECH (mm) / ALL DIMENSIONS IN MILLIMETERS (mm)			
POVRCH. ÚPRAVA / SURF. FINISH:		chemicky zpevněno / chemically strengthened		NÁZEV SOUBORU: FILE NAME:		HT 4691-01-00 Design.cdr	
VYPRACOVAL / DRAWN:		L.Mlateček		TOLERANCE:		ISO 2768 mK	
TECHNOLOG / CHECKED:		DATUM / DATE:		07.12.2015		FORMÁT: ORIGINAL SIZE:	
akí ELECTRONIC spol. s r.o. Znojemská 94 586 01 Jihlava Czech Republic		NÁZEV: TITLE:		Design		ČÍSLO VÝKRESU: DRAWING NUMBER:	
				HT 4691-01-00		LIST / LISTŮ: SHEET / SHEETS:	
						1/1	

Reprodukování, šíření a poskytnutí tohoto dokumentu, jeho částí nebo obsahu třetí osobě je bez výslovného souhlasu zakázáno. Porušení zákazu vede k odpovědnosti za vzniklou škodu. Všechna práva jsou vyhrazena rovněž v případech registrovaného patentu, průmyslového vzoru nebo výtvarného návrhu. / The reproduction, distribution and utilization of this document as well as the communication of its contents to others without express authorization is prohibited. Offenders will be held liable for the payment of damages. All rights reserved in the event of the grant of a patent, utility model or design.

Elektronický originál v IS Helios. Papírové kopie jsou neplatné pro výrobu, pokud nejsou označeny číslem kopie a datem.

1 2 3 4 5 6 7 8

Durable Anti-Fingerprint Coating on Anti-Reflective Cover Glass

DARO* coating minimizing fingerprints – the breakthrough for any professional touch application – now available on CONTURAN®

SCHOTT has developed a new coating combination with durable anti-reflective, anti-fingerprint, easy to clean and anti-smudge (oleo- & hydrophobic) characteristics, a breakthrough for any professional touch application.

Anti-reflective coatings are significantly enhancing the contrast of today's high resolution displays, but their usage in touch applications suffers from the issue of fingerprint visibility on the surface of such low-reflective glass.

The availability of a super tough and super durable anti-fingerprint coating, along with an anti-reflective coating has been requested for a long time and is now being offered by SCHOTT on its well known material CONTURAN®, now available as CONTURAN® DARO.

SCHOTT is well equipped to deliver cut-to-size materials with complex edge-processing, screen-printing (organic and ceramic colors are available) and tempering or chemical hardening. We're looking forward to support your products with our expertise.



Applications

- Touch-screen displays
- Ruggedized displays
- Command and control displays
- Medical displays
- GPS displays (e. g. automotive)
- Kiosks/Public displays
- Gaming displays

Advantages

- Anti-reflective
- Anti-fingerprint
- Durable
- Easy-to-clean
- Water repellent
- Great haptics

Long-term Durability

In order to use an AR coating in a touch application it must have an oleophobic coating that can withstand hundreds of thousands of finger touches and rubs. CONTURAN® DARO fulfills this demand and maintains its properties such as reduced visibility of fingerprints, easy-to-clean properties and good haptics even if subjected to harsh mechanical and chemical stress.

Proof of Durability for Touch Applications

- Inherently resistant to salt spray environments; more than 90 days
- Rub resistance greater than 400,000 rubs per MIL-C-675C (equals >20 years lifetime based on 10 cleaning cycles per day with 5 rubs/cycle)

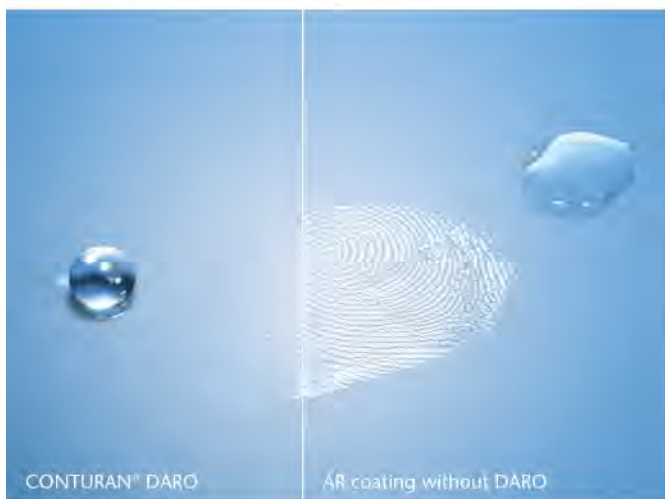

*DARO stands for Durable Anti-Reflective Oleophobic

CONTURAN® DARO

Surfaces of touch-screens need to withstand hundreds of thousands of finger touches. Touching the surface leads to mechanical abrasion and to chemical wear because of salt in the sweat on our fingers. In order to prove the durability of CONTURAN® DARO we perform mechanical abrasive tests (cheesecloth rubs) as well as chemical resistance tests (salt spray):

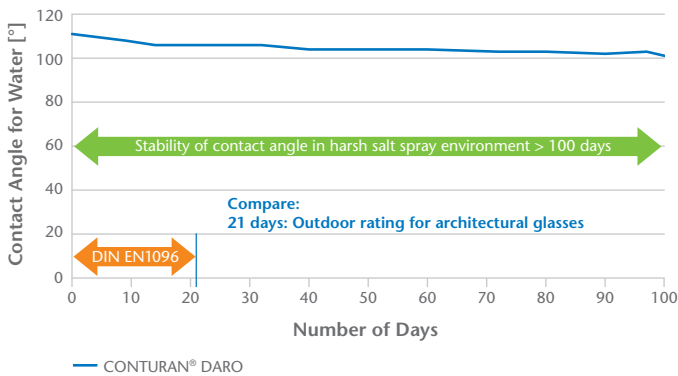
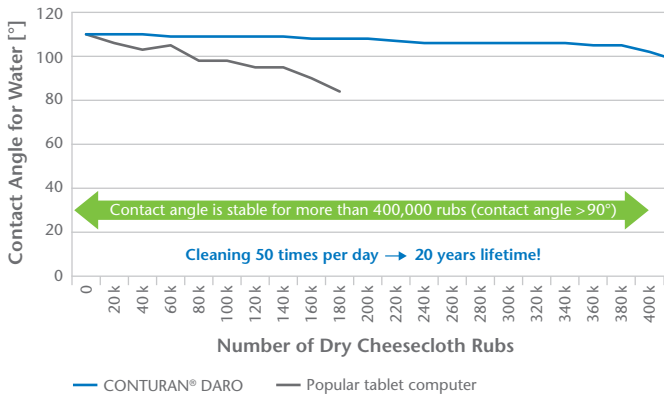

ABREX® test:

A combination of mechanical and chemical wear is simulated by the ABREX® test commonly used in the automotive industry, tested using artificial sweat. CONTURAN® DARO slightly surpasses the performance of painted plastic parts in automotive industry (e.g. for gear selectors) according to DIN EN 60068-2-70 / IEC 68-2-70. CONTURAN® DARO can be used on the gear selector in your car and the oleophobic coating will stand the lifetime of your vehicle.

In addition SCHOTT's R&D has developed a method to characterize the fingerprint adhesion on untreated and treated glass sheets. With this test procedure it is possible to get reproducible and quantitative results of the amount of fingerprint transfer onto defined substrates.

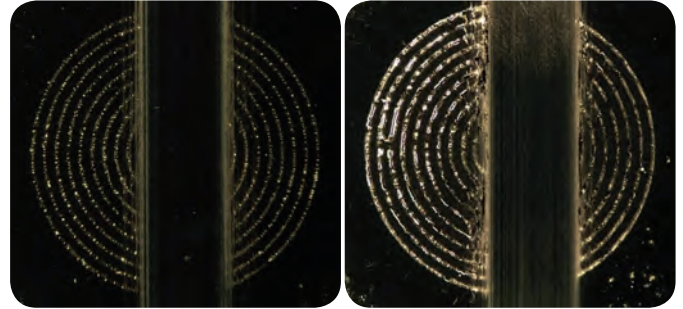

Equal applied imprint on CONTURAN® DARO respectively AR-Glass (both glasses wiped dry 3 times)

Specifications (Dimensions & product range)
Glass thickness from 1.1 mm up to 6.0 mm
Available in sizes up to 990 mm x 1,770 mm (72" diagonal)
CONTURAN® Standard
CONTURAN® Magic
CONTURAN® Grey
CONTURAN® BOROFLOAT®
Can be combined with all necessary processing as screen printing, tempering, laminating etc.



Advanced Optics
SCHOTT AG
 Hattenbergstrasse 10
 55122 Mainz
 Germany
 Phone +49 (0)6131/66-1812
 Fax +49 (0)3641/2888-9047
 info.optics@schott.com

www.schott.com/advanced_optics



EXAMINED BY :	EMERGING DISPLAY TECHNOLOGIES CORPORATION	FILE NO . CAS-0008203
Lucica Lu		ISSUE : APR.06, 2016
APPROVED BY:		TOTAL PAGE : 30
Vincent Wh		VERSION : 3

CUSTOMER ACCEPTANCE SPECIFICATIONS

MODEL NO. :

ETM0700G0EDH6

(RoHS)

FOR MESSRS :

CUSTOMER'S APPROVAL

DATE :

BY :

RECORDS OF REVISION	DOC . FIRST ISSUE	DEC.16, 2015
---------------------	-------------------	--------------

DATE	REVISED PAGE NO.	SUMMARY																																																																																																																																																										
JAN.18, 2016	14	10.1 IF1 : PIN 26~28 : ADD DE MODE : HSYNC, VSYNC CONNECTED TO VDD. SYNC MODE : ENB CONNECTED TO GROUND.																																																																																																																																																										
APR.06, 2016	7	5.4 CAPACITIVE TOUCH PANEL I2C INTERFACE TIMING CHARACTERISTICS SCL FREQUENCY : MIN.=0 → —																																																																																																																																																										
	9	<p>6.1 OPTICAL CHARACTERISTICS</p> <table border="1"> <thead> <tr> <th>ITEM</th> <th>SYMBOL</th> <th>CONDITION</th> <th>MIN.</th> <th>TYP.</th> <th>MAX.</th> <th>UNIT</th> <th>REMARK</th> </tr> </thead> <tbody> <tr> <td rowspan="3">VIEWING ANGLE</td> <td>θ_v</td> <td rowspan="3">CR ≥ 10</td> <td>$\theta_v=0^\circ$</td> <td>(70)</td> <td>(80)</td> <td>—</td> <td rowspan="3">deg. NOTE (2) NOTE (3)</td> </tr> <tr> <td>θ_h</td> <td>(70)</td> <td>(80)</td> <td>—</td> </tr> <tr> <td>θ_d</td> <td>(70)</td> <td>(80)</td> <td>—</td> </tr> <tr> <td>CONTRAST RATIO</td> <td>CR</td> <td>$\theta_x=0^\circ, \theta_y=0^\circ$</td> <td>(300)</td> <td>(350)</td> <td>—</td> <td>—</td> <td>NOTE (3)</td> </tr> <tr> <td rowspan="6">COLOR OF CIE COORDINATE</td> <td rowspan="2">WHITE</td> <td rowspan="6">$\theta_x=0^\circ, \theta_y=0^\circ$ IF = 160 mA NTSC : 72 %</td> <td>Wx</td> <td>(0.25)</td> <td>(0.30)</td> <td>(0.35)</td> <td rowspan="6">—</td> <td rowspan="6">NOTE (5)</td> </tr> <tr> <td>Wy</td> <td>(0.29)</td> <td>(0.34)</td> <td>(0.39)</td> </tr> <tr> <td>RED</td> <td>Rx</td> <td>(0.59)</td> <td>(0.64)</td> <td>(0.69)</td> </tr> <tr> <td>GREEN</td> <td>Ry</td> <td>(0.30)</td> <td>(0.35)</td> <td>(0.40)</td> </tr> <tr> <td>Gx</td> <td>(0.27)</td> <td>(0.32)</td> <td>(0.37)</td> </tr> <tr> <td>BLUE</td> <td>Gy</td> <td>(0.60)</td> <td>(0.65)</td> <td>(0.70)</td> </tr> <tr> <td>THE BRIGHTNESS OF MODULE</td> <td>B</td> <td>$\theta_x=0^\circ, \theta_y=0^\circ$ IF = 160mA</td> <td>(0.11)</td> <td>(0.16)</td> <td>(0.21)</td> <td>—</td> <td>—</td> <td>(0.02)</td> <td>(0.07)</td> <td>(0.12)</td> <td>cd/m²</td> <td>NOTE (6)</td> </tr> </tbody> </table> <table border="1"> <thead> <tr> <th>ITEM</th> <th>SYMBOL</th> <th>CONDITION</th> <th>MIN.</th> <th>TYP.</th> <th>MAX.</th> <th>UNIT</th> <th>REMARK</th> </tr> </thead> <tbody> <tr> <td rowspan="3">VIEWING ANGLE</td> <td>θ_v</td> <td rowspan="3">CR ≥ 10</td> <td>$\theta_v=0^\circ$</td> <td>65</td> <td>70</td> <td>—</td> <td rowspan="3">deg. NOTE (2) NOTE (3)</td> </tr> <tr> <td>θ_h</td> <td>70</td> <td>75</td> <td>—</td> </tr> <tr> <td>θ_d</td> <td>70</td> <td>75</td> <td>—</td> </tr> <tr> <td>CONTRAST RATIO</td> <td>CR</td> <td>$\theta_x=0^\circ, \theta_y=0^\circ$</td> <td>675</td> <td>900</td> <td>—</td> <td>—</td> <td>NOTE (3)</td> </tr> <tr> <td rowspan="6">COLOR OF CIE COORDINATE</td> <td rowspan="2">WHITE</td> <td rowspan="6">$\theta_x=0^\circ, \theta_y=0^\circ$ IF = 160 mA NTSC : 72 %</td> <td>Wx</td> <td>0.255</td> <td>0.305</td> <td>0.355</td> <td rowspan="6">—</td> <td rowspan="6">NOTE (5)</td> </tr> <tr> <td>Wy</td> <td>0.275</td> <td>0.325</td> <td>0.375</td> </tr> <tr> <td>RED</td> <td>Rx</td> <td>0.585</td> <td>0.635</td> <td>0.685</td> </tr> <tr> <td>GREEN</td> <td>Ry</td> <td>0.295</td> <td>0.345</td> <td>0.395</td> </tr> <tr> <td>Gx</td> <td>0.265</td> <td>0.315</td> <td>0.365</td> </tr> <tr> <td>BLUE</td> <td>Gy</td> <td>0.595</td> <td>0.645</td> <td>0.695</td> </tr> <tr> <td>THE BRIGHTNESS OF MODULE</td> <td>B</td> <td>$\theta_x=0^\circ, \theta_y=0^\circ$ IF = 160mA</td> <td>0.115</td> <td>0.165</td> <td>0.215</td> <td>—</td> <td>—</td> <td>0.020</td> <td>0.070</td> <td>0.120</td> <td>cd/m²</td> <td>NOTE (6)</td> </tr> </tbody> </table>	ITEM	SYMBOL	CONDITION	MIN.	TYP.	MAX.	UNIT	REMARK	VIEWING ANGLE	θ_v	CR ≥ 10	$\theta_v=0^\circ$	(70)	(80)	—	deg. NOTE (2) NOTE (3)	θ_h	(70)	(80)	—	θ_d	(70)	(80)	—	CONTRAST RATIO	CR	$\theta_x=0^\circ, \theta_y=0^\circ$	(300)	(350)	—	—	NOTE (3)	COLOR OF CIE COORDINATE	WHITE	$\theta_x=0^\circ, \theta_y=0^\circ$ IF = 160 mA NTSC : 72 %	Wx	(0.25)	(0.30)	(0.35)	—	NOTE (5)	Wy	(0.29)	(0.34)	(0.39)	RED	Rx	(0.59)	(0.64)	(0.69)	GREEN	Ry	(0.30)	(0.35)	(0.40)	Gx	(0.27)	(0.32)	(0.37)	BLUE	Gy	(0.60)	(0.65)	(0.70)	THE BRIGHTNESS OF MODULE	B	$\theta_x=0^\circ, \theta_y=0^\circ$ IF = 160mA	(0.11)	(0.16)	(0.21)	—	—	(0.02)	(0.07)	(0.12)	cd/m ²	NOTE (6)	ITEM	SYMBOL	CONDITION	MIN.	TYP.	MAX.	UNIT	REMARK	VIEWING ANGLE	θ_v	CR ≥ 10	$\theta_v=0^\circ$	65	70	—	deg. NOTE (2) NOTE (3)	θ_h	70	75	—	θ_d	70	75	—	CONTRAST RATIO	CR	$\theta_x=0^\circ, \theta_y=0^\circ$	675	900	—	—	NOTE (3)	COLOR OF CIE COORDINATE	WHITE	$\theta_x=0^\circ, \theta_y=0^\circ$ IF = 160 mA NTSC : 72 %	Wx	0.255	0.305	0.355	—	NOTE (5)	Wy	0.275	0.325	0.375	RED	Rx	0.585	0.635	0.685	GREEN	Ry	0.295	0.345	0.395	Gx	0.265	0.315	0.365	BLUE	Gy	0.595	0.645	0.695	THE BRIGHTNESS OF MODULE	B	$\theta_x=0^\circ, \theta_y=0^\circ$ IF = 160mA	0.115	0.165	0.215	—	—	0.020	0.070	0.120	cd/m ²	NOTE (6)
ITEM	SYMBOL	CONDITION	MIN.	TYP.	MAX.	UNIT	REMARK																																																																																																																																																					
VIEWING ANGLE	θ_v	CR ≥ 10	$\theta_v=0^\circ$	(70)	(80)	—	deg. NOTE (2) NOTE (3)																																																																																																																																																					
	θ_h		(70)	(80)	—																																																																																																																																																							
	θ_d		(70)	(80)	—																																																																																																																																																							
CONTRAST RATIO	CR	$\theta_x=0^\circ, \theta_y=0^\circ$	(300)	(350)	—	—	NOTE (3)																																																																																																																																																					
COLOR OF CIE COORDINATE	WHITE	$\theta_x=0^\circ, \theta_y=0^\circ$ IF = 160 mA NTSC : 72 %	Wx	(0.25)	(0.30)	(0.35)	—	NOTE (5)																																																																																																																																																				
			Wy	(0.29)	(0.34)	(0.39)																																																																																																																																																						
	RED		Rx	(0.59)	(0.64)	(0.69)																																																																																																																																																						
	GREEN		Ry	(0.30)	(0.35)	(0.40)																																																																																																																																																						
	Gx		(0.27)	(0.32)	(0.37)																																																																																																																																																							
	BLUE		Gy	(0.60)	(0.65)	(0.70)																																																																																																																																																						
THE BRIGHTNESS OF MODULE	B	$\theta_x=0^\circ, \theta_y=0^\circ$ IF = 160mA	(0.11)	(0.16)	(0.21)	—	—	(0.02)	(0.07)	(0.12)	cd/m ²	NOTE (6)																																																																																																																																																
ITEM	SYMBOL	CONDITION	MIN.	TYP.	MAX.	UNIT	REMARK																																																																																																																																																					
VIEWING ANGLE	θ_v	CR ≥ 10	$\theta_v=0^\circ$	65	70	—	deg. NOTE (2) NOTE (3)																																																																																																																																																					
	θ_h		70	75	—																																																																																																																																																							
	θ_d		70	75	—																																																																																																																																																							
CONTRAST RATIO	CR	$\theta_x=0^\circ, \theta_y=0^\circ$	675	900	—	—	NOTE (3)																																																																																																																																																					
COLOR OF CIE COORDINATE	WHITE	$\theta_x=0^\circ, \theta_y=0^\circ$ IF = 160 mA NTSC : 72 %	Wx	0.255	0.305	0.355	—	NOTE (5)																																																																																																																																																				
			Wy	0.275	0.325	0.375																																																																																																																																																						
	RED		Rx	0.585	0.635	0.685																																																																																																																																																						
	GREEN		Ry	0.295	0.345	0.395																																																																																																																																																						
	Gx		0.265	0.315	0.365																																																																																																																																																							
	BLUE		Gy	0.595	0.645	0.695																																																																																																																																																						
THE BRIGHTNESS OF MODULE	B	$\theta_x=0^\circ, \theta_y=0^\circ$ IF = 160mA	0.115	0.165	0.215	—	—	0.020	0.070	0.120	cd/m ²	NOTE (6)																																																																																																																																																
	14	<p>10.1 IF1</p> <table border="1"> <thead> <tr> <th>PIN NO.</th> <th>SYMBOL</th> <th>I/O P</th> <th>FUNCTION</th> </tr> </thead> <tbody> <tr> <td>25</td> <td>WAKE</td> <td>I</td> <td>EXTERNAL INTERRUPT FROM THE HOST TOUCH PANEL</td> </tr> </tbody> </table> <table border="1"> <thead> <tr> <th>PIN NO.</th> <th>SYMBOL</th> <th>I/O P</th> <th>FUNCTION</th> </tr> </thead> <tbody> <tr> <td>25</td> <td>NC</td> <td>—</td> <td>NON CONNECTION</td> </tr> </tbody> </table>	PIN NO.	SYMBOL	I/O P	FUNCTION	25	WAKE	I	EXTERNAL INTERRUPT FROM THE HOST TOUCH PANEL	PIN NO.	SYMBOL	I/O P	FUNCTION	25	NC	—	NON CONNECTION																																																																																																																																										
PIN NO.	SYMBOL	I/O P	FUNCTION																																																																																																																																																									
25	WAKE	I	EXTERNAL INTERRUPT FROM THE HOST TOUCH PANEL																																																																																																																																																									
PIN NO.	SYMBOL	I/O P	FUNCTION																																																																																																																																																									
25	NC	—	NON CONNECTION																																																																																																																																																									

TABLE OF CONTENTS

NO.	ITEM	PAGE
1.	GENERAL SPECIFICATIONS -----	1
2.	MECHANICAL SPECIFICATIONS -----	1
3.	ABSOLUTE MAXIMUM RATINGS -----	2
4.	ELECTRICAL CHARACTERISTICS -----	3
5.	TIMING CHARACTERISTICS -----	4 ~ 8
6.	OPTICAL CHARACTERISTICS -----	9, 10
7.	OUTLINE DIMENSIONS -----	11
8.	BLOCK DIAGRAM -----	12
9.	DETAIL DRAWING OF DOT MATRIX -----	13
10.	INTERFACE SIGNALS -----	14, 15
11.	POWER SUPPLY -----	16
12.	CAPACITIVE TOUCH PANEL SPECIFICATION -----	16 ~ 20
13.	INSPECTION CRITERION -----	21 ~ 30

CONFIDENTIAL
 Authorized for
 Emerging Display Technologies Corporation Only.
 Do not distribute without authorization.

1. GENERAL SPECIFICATIONS

1.1 DATA SHEETS FOR LCD MODULE CONTROLLER/DRIVER PLEASE REFER TO :

HIMAX HX8262-A
HIMAX HX8678-A

1.2 DATA SHEET FOR CAPACITIVE TOUCH PANEL CONTROLLER/DRIVER PLEASE REFER TO :

HYCON HY4614

1.3 MATERIAL SAFETY DESCRIPTION

ASSEMBLIES SHALL COMPLY WITH EUROPEAN ROHS REQUIREMENTS, INCLUDING PROHIBITED MATERIALS/COMPONENTS CONTAINING LEAD, MERCURY, CADMIUM, HEXAVALENT CHROMIUM, POLYBROMINATED BIPHENYLS (PBB) AND POLYBROMINATED DIPHENYL ETHERS (PBDE)

2. MECHANICAL SPECIFICATIONS

2.1 LCD MODULE MECHANICAL SPECIFICATIONS

(1) DIAGONALS	-----	7 inch
(2) NUMBER OF DOTS	-----	800W * (RGB) * 480H DOTS
(3) MODULE SIZE	-----	166W * 105.44H * 11.6D (MAX.) mm (WITHOUT FPC & LED BL'S CABLE)
(4) EFFECTIVE AREA	-----	154.4W * 93.44H mm
(5) ACTIVE AREA	-----	152.4W * 91.44H mm
(6) DOT SIZE	-----	0.0635W * 0.1905H mm
(7) PIXEL SIZE	-----	0.1905W * 0.1905H mm
(8) LCD TYPE	-----	TFT , TRANSMISSIVE , ANTI-GLARE
(9) COLOR	-----	262K
(10) VIEWING DIRECTION	-----	6 O'CLOCK (GRAY LEVEL INVERSION)
(11) BACK LIGHT	-----	LED , COLOR : WHITE
(12) INTERFACE MODE	-----	RGB 18BIT PARALLEL (DE/SYNC MODE)

2.2 CAPACITIVE TOUCH PANEL MECHANICAL SPECIFICATIONS

(1) TOUCH PANEL SIZE	-----	7.0 inch
(2) OUTER DIMENSION	-----	164W * 104H * 1.4D mm (WITHOUT FPC)
(3) EFFECTIVE AREA	-----	155W * 94.045H mm
(4) ACTIVE AREA	-----	154W * 93.05H mm
(5) INPUT TYPE	-----	MULTI TOUCH
(6) NUMBER OF TOUCH SENSOR	-----	28 * 16 SENSORS
(7) RESOLUTION	-----	1792 * 1024
(8) INTERFACE MODE	-----	I2C

3. ABSOLUTE MAXIMUM RATINGS

3.1 ELECTRICAL ABSOLUTE MAXIMUM RATINGS

ITEM	SYMBOL	MIN.	MAX.	UNIT	REMARK
POWER SUPPLY VOLTAGE	VDD-VSS	-0.3	3.6	V	
INPUT VOLTAGE	VIN-VSS	-0.3	VDD+0.3	V	
STATIC ELECTRICITY	—	—	—	V	NOTE (1)
LED BACKLIGHT POWER DISSIPATION	PD	—	2592	mW	
LED BACKLIGHT FORWARD CURRENT	IF	—	240	mA	

NOTE (1) : LCM SHOULD BE GROUNDED DURING HANDLING LCM.

3.2 ENVIRONMENTAL ABSOLUTE MAXIMUM RATINGS

ITEM	OPERATING		STORAGE		REMARK
	MIN.	MAX.	MIN.	MAX.	
AMBIENT TEMPERATURE	-20°C	70°C	-30°C	80°C	NOTE (1), (2)
HUMIDITY	NOTE (3)		NOTE (3)		WITHOUT CONDENSATION
VIBRATION	—	2.45 m/s ² (0.25 G)	—	11.76 m/s ² (1.2 G)	5~20Hz, 1HR 20~500Hz(20Hz), 1HR 20~500Hz(500Hz), 1HR X,Y,Z TOTAL 3HRS
SHOCK	—	29.4 m/s ² (3 G)	—	490.0 m/s ² (50 G)	10ms XYZ DIRECTIONS 1 TIME EACH
CORROSIVE GAS	NOT ACCEPTABLE		NOT ACCEPTABLE		

NOTE (1) : Ta AT -30°C : WILL BE 48HRS MAX .

80°C : WILL BE 168HRS MAX .

NOTE (2) : BACKGROUND COLOR CHANGES SLIGHTLY DEPENDING ON AMBIENT TEMPERATURE
THIS PHENOMENON IS REVERSIBLE.

NOTE (3) : Ta ≤ 60°C : 90%RH MAX (96HRS MAX).

Ta > 60°C : ABSOLUTE HUMIDITY MUST BE LOWER THAN THE HUMIDITY
OF 90%RH AT 60°C(96HRS MAX).

4. ELECTRICAL CHARACTERISTICS

Ta = 25 °C

ITEM	SYMBOL	CONDITION	MIN.	TYP.	MAX.	UNIT	REMARK
POWER SUPPLY VOLTAGE	VDD-VSS	—	3.2	3.3	3.6	V	
POWER SUPPLY VOLTAGE FOR LED DRIVER	VCC-VSS	—	3.0	3.3	3.6	V	
HIGH LEVEL INPUT VOLTAGE	VIH	—	0.7*VDD	—	VDD	V	NOTE (1)
LOW LEVEL INPUT VOLTAGE	VIL	—	0	—	0.3*VDD	V	NOTE (1)
POWER SUPPLY CURRENT	IDD	VDD-VSS=3.3V	—	240	300	mA	NOTE (2)
POWER SUPPLY CURRENT FOR LED DRIVER	ICC	VCC-VSS=3.3V LED B/L=ON	—	600	780	mA	
POWER SUPPLY FOR LED BACKLIGHT	V _{BL+} -V _{BL-}	IF=160mA	8.4	9.9	10.8	V	NOTE (3)
LED LIFE TIME	—	—	30K	40K	—	HRS	

NOTE (1) : APPLIED TO TERMINALS B5~B0 , G5~G0 , R5~R0 , DCLK , HSYNC , VSYNC , ENB.

NOTE (2) : THE DISPLAY PATTERN IS ALL "WHITE"..

NOTE (3) : INTERNAL CIRCUIT DIAGRAM OF BACKLIGHT

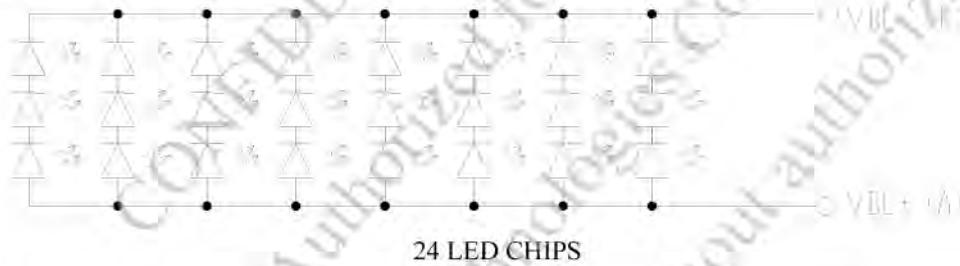

NOTE (4) : AMBIENT TEMP. VS. ALLOWABLE FORWARD CURRENT. (PER. LED)

Ambient Temperature vs.
Allowable Forward Current

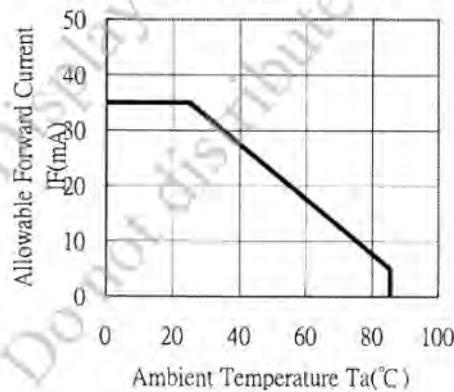

5. TIMING CHARACTERISTICS

5.1 LCD MODULE AC ELECTRICAL CHARACTERISTICS

ITEM	SYMBOL	MIN.	TYP.	MAX.	UNIT
HSYNC SETUP TIME	T_{hst}	6	—	—	ns
HSYNC HOLD TIME	T_{hhd}	6	—	—	ns
VSYNC SETUP TIME	T_{vst}	6	—	—	ns
VSYNC HOLD TIME	T_{vhhd}	6	—	—	ns
DATA SETUP TIME	T_{dsu}	6	—	—	ns
DATA HOLD TIME	T_{dhd}	6	—	—	ns
ENB SETUP TIME	T_{esu}	6	—	—	ns
SOURCE OUTPUT SETTLING TIME	T_{ST}	—	—	15	μs
SOURCE OUTPUT LOADING R	R_{SL}	—	2	—	K ohm
SOURCE OUTPUT LOADING C	C_{SL}	—	60	—	pF

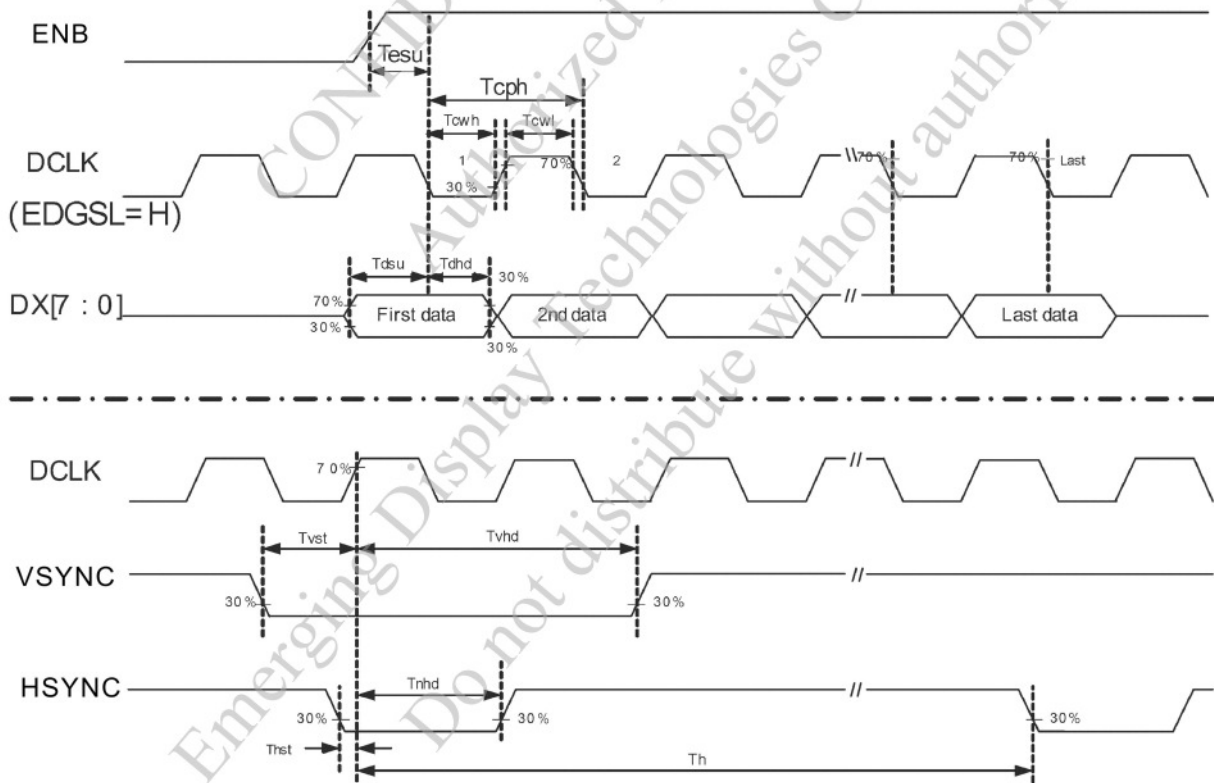

5.2 LCD MODULE SYNC MODE SIGNAL CHARACTERISTICS

ITEM	SYMBOL	MIN.	TYP.	MAX.	UNIT
DCLK FREQUENCY	F_{CPH}	—	33.26	—	MHz
DCLK PERIOD	T_{CPH}	—	30.06	—	ns
DCLK PULSE DUTY	T_{CWH}	40	50	60	%
HSYNC PERIOD	T_H	930	1056	1057	T_{CPH}
HSYNC PULSE WIDTH	T_{WH}	1	128	—	T_{CPH}
HSYNC -FIRST HORIZONTAL DATA TIME	T_{HS}	—	216	—	T_{CPH}
HSYNC ACTIVE TIME	T_{HA}	—	800	—	T_{CPH}
VSYNC PERIOD	T_V	—	525	—	T_H
VSYNC PULSE WIDTH	T_{WV}	1	2	—	T_H
VSYNC -DE TIME	T_{VS}	—	35	—	T_H
VSYNC ACTIVE TIME	T_{VA}	—	480	—	T_H

(EDGSL=H)

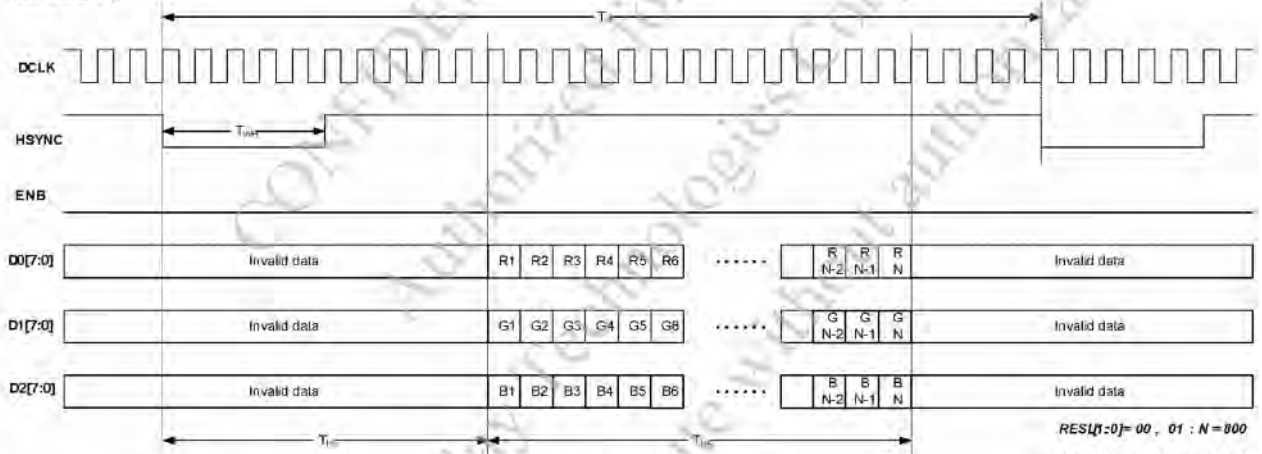

SYNC Mode Horizontal Data Format

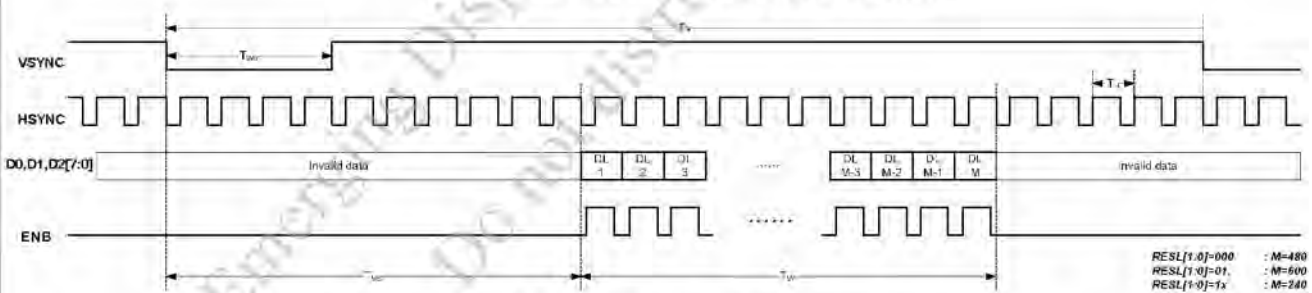

SYNC Mode Vertical Data Format

5.3 LCD MODULE DE MODE SIGNAL CHARACTERISTICS

ITEM	SYMBOL	MIN.	TYP.	MAX.	UNIT
DCLK FREQUENCY	F_{CPH}	—	33.26	—	MHZ
DCLK PERIOD	T_{CPH}	—	30.06	—	ns
DCLK PULSE DUTY	T_{CWH}	40	50	60	%
ENB PERIOD	$T_{DEH} + T_{DEL}$	1000	1056	1200	T_{CPH}
ENB PULSE WIDTH	T_{DEH}	—	800	—	T_{CPH}
ENB FRAME BLANKING	T_{DEB}	10	45	110	$T_{DEH} + T_{DEL}$
ENB FRAME WIDTH	T_{DE}	—	480	—	$T_{DEH} + T_{DEL}$
OEV PULSE WIDTH	T_{OEV}	—	150	—	T_{CPH}
CKV PULSE WIDTH	T_{CKV}	—	133	—	T_{CPH}
ENB(INTERNAL)-STV TIME	T_1	—	4	—	T_{CPH}
ENB(INTERNAL)-CKV TIME	T_2	—	40	—	T_{CPH}
ENB(INTERNAL)-OEV TIME	T_3	—	23	—	T_{CPH}
ENB(INTERNAL)-POL TIME	T_4	—	157	—	T_{CPH}
STV PULSE WIDTH	—	—	1	—	T_H

NOTE (1) : $T_{HS} + T_{HA} < T_H$

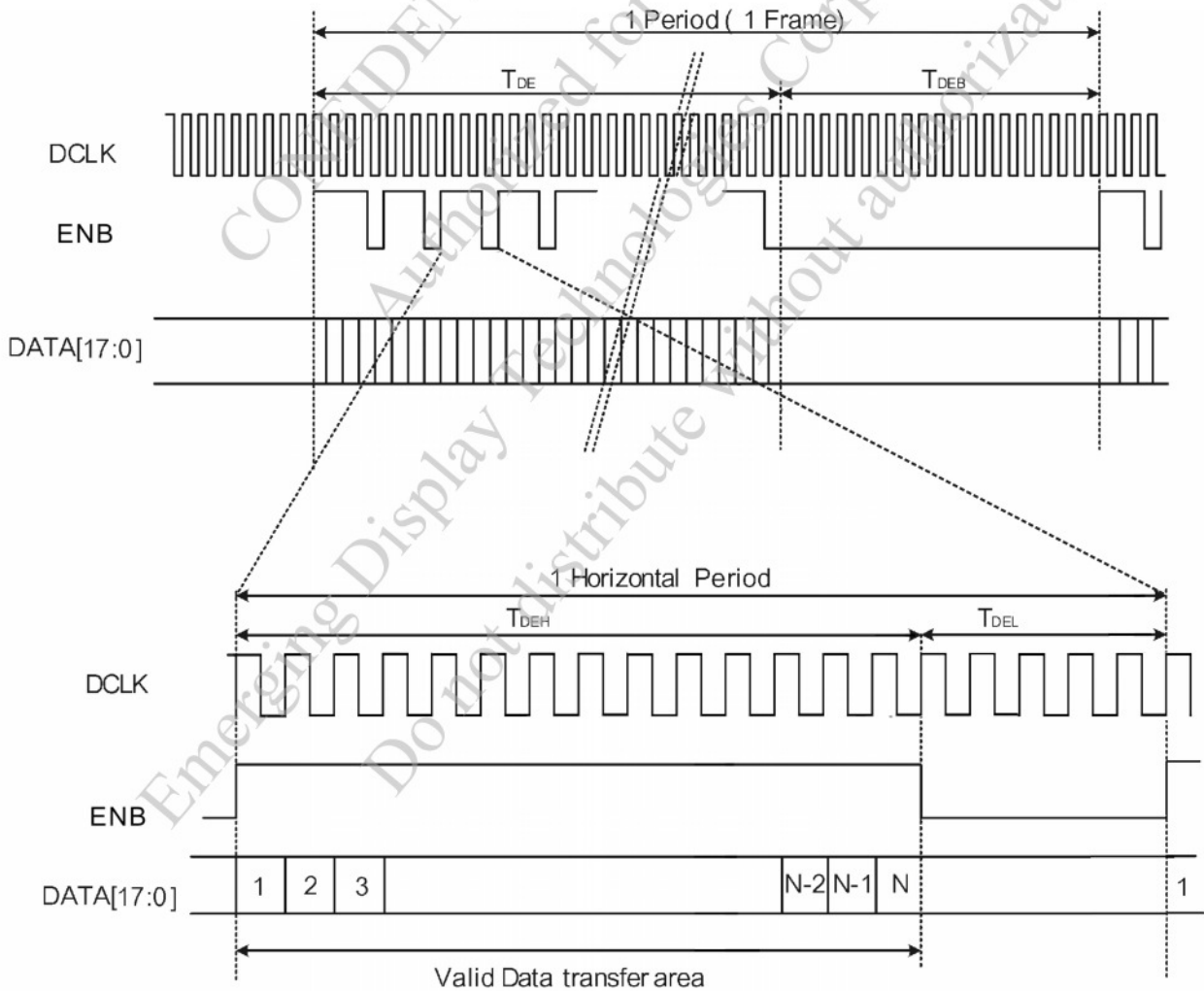

5.4 CAPACITIVE TOUCH PANEL I2C INTERFACE TIMING CHARACTERISTICS

ITEM	MIN.	TYP.	MAX.	UNIT
SCL FREQUENCY	—	—	400	KHz
BUS FREE TIME BETWEEN A STOP AND START CONDITION	1.3	—	—	us
HOLD TIME (REPEATED) START CONDITION	0.6	—	—	us
DATA SETUP TIME	100	—	—	ns
SETUP TIME FOR A REPEATED START CONDITION	0.6	—	—	us
SETUP TIME FOR STOP CONDITION	0.6	—	—	us

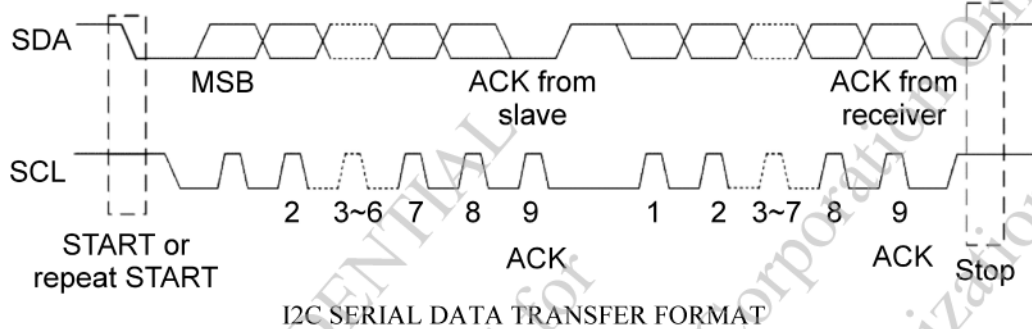

CONFIDENTIAL
Authorized for
Emerging Display Technologies Corporation Only
Do not distribute without authorization.

5.5 CAPACITIVE TOUCH PANEL POWER SEQUENCE

ITEM	SYMBOL	MIN.	TYP.	MAX.	UNIT
RISE TIME FROM 0.1VDD TO 0.9VDD	Tris	—	—	5	ms
TIME OF RESETTING TO BE LOW BEFORE POWERING ON	Trtp	100	—	—	us
TIME OF STARTING TO REPORT POINT AFTER POWERING ON	Tpon	200	—	—	ms
RESET TIME AFTER VDD POWERING ON	Tvdr	1	—	—	ms
TIME OF STARTING TO REPORT POINT AFTER RESETTING	Trsi	200	—	—	ms
RESET TIME	Trst	2	—	—	ms

POWER RISE TIMING

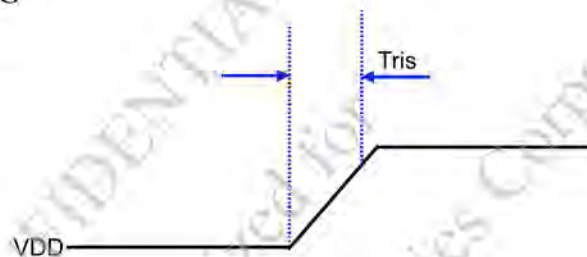

POWER ON / OFF TIMING

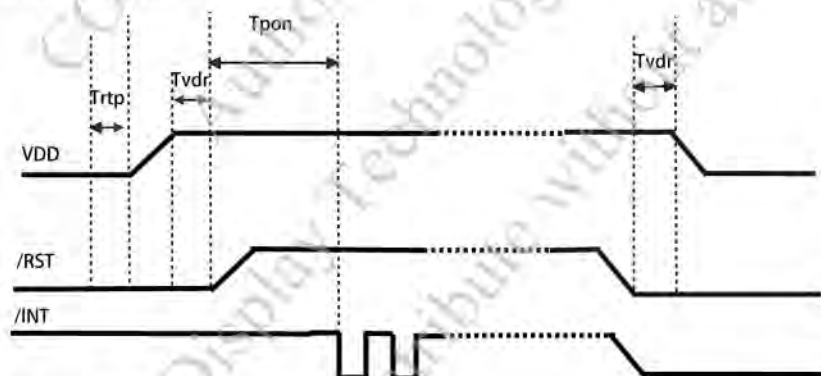

RESET SEQUENCE

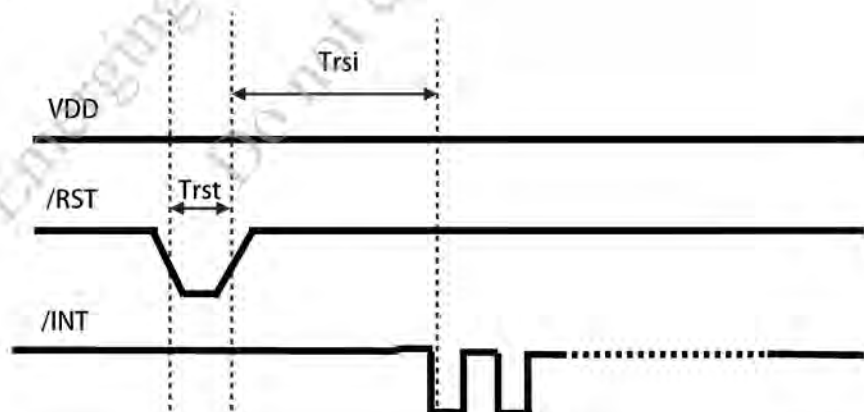

6. OPTICAL CHARACTERISTICS (NOTE 1)

6.1 OPTICAL CHARACTERISTICS

Ta = 25 ± 2 °C

ITEM		SYMBOL	CONDITION	MIN.	TYP.	MAX.	UNIT	REMARK
VIEWING ANGLE		θ_{y+}	$\theta_x=0^\circ$	65	70	—	deg.	NOTE (2) NOTE (3)
		θ_{y-}		70	75	—		
		θ_{x+}	$\theta_y=0^\circ$	70	75	—		
		θ_{x-}		70	75	—		
CONTRAST RATIO		CR	$\theta_x=0^\circ, \theta_y=0^\circ$	675	900	—	—	NOTE (3)
RESPONSE TIME		T_R (rise)	$\theta_x=0^\circ, \theta_y=0^\circ$	—	5	10	msec	NOTE (4)
		T_F (fall)		—	15	20		
COLOR OF CIE COORDINATE	WHITE	W_x	$\theta_x=0^\circ, \theta_y=0^\circ$ IF = 160 mA NTSC : 72 %	0.255	0.305	0.355	—	NOTE (5)
		W_y		0.275	0.325	0.375		
	RED	R_x		0.585	0.635	0.685	—	
		R_y		0.295	0.345	0.395		
	GREEN	G_x		0.265	0.315	0.365	—	
		G_y		0.595	0.645	0.695		
	BLUE	B_x		0.115	0.165	0.215	—	
		B_y		0.020	0.070	0.120		
THE BRIGHTNESS OF MODULE		B	$\theta_x=0^\circ, \theta_y=0^\circ$	308	352	—	cd/m ²	NOTE (6)
THE UNIFORMITY OF MODULE		—	IF = 160mA	75	80	—	%	

NOTE (1) : TEST EQUIPMENT SETUP :

AFTER STABILIZING AND LEAVING THE PANEL ALONE AT A GIVEN TEMPERATURE FOR 30 MINUTES, THE MEASUREMENT SHOULD BE EXECUTED. MEASUREMENT SHOULD BE EXECUTED IN A STABLE, WINDLESS, AND DARK ROOM. OPTICAL SPECIFICATIONS ARE MEASURED BY TOPCON BM-7 (FAST) WITH A VIEWING ANGLE OF 1° AT A DISTANCE OF 50cm AND NORMAL DIRECTION.

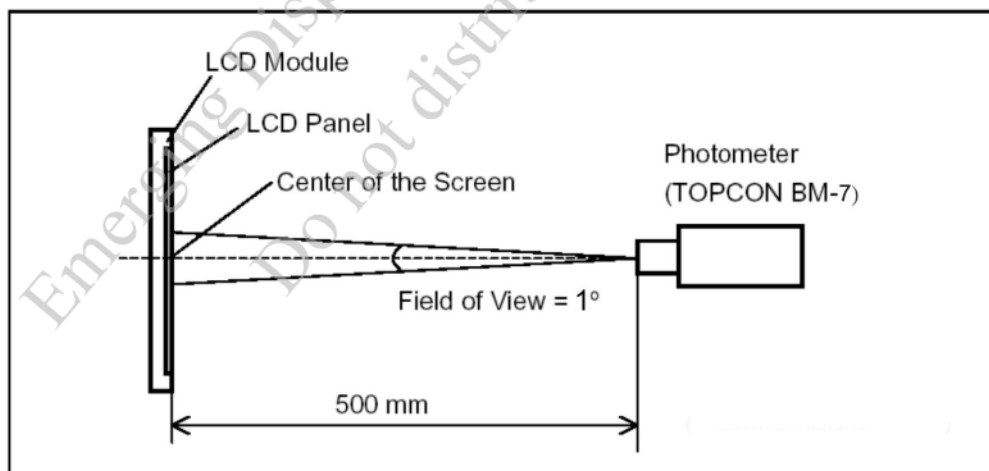

NOTE (2) : DEFINITION OF VIEWING ANGLE :

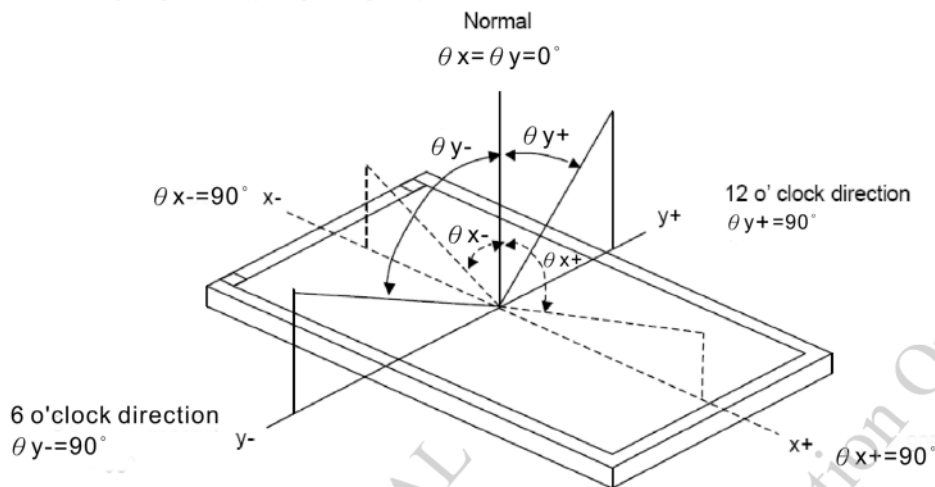

NOTE (3) : DEFINITION OF CONTRAST RATIO :

$$\text{CONTRAST RATIO(CR)} = \frac{\text{BRIGHTNESS MEASURED WHEN LCD IS AT "WHITE STATE"}}{\text{BRIGHTNESS MEASURED WHEN LCD IS AT "BLACK STATE"}}$$

NOTE (4) : DEFINITION OF RESPONSE TIME : T_R AND T_F

THE FIGURE BELOW IS THE OUTPUT SIGNAL OF THE PHOTO DETECTOR.

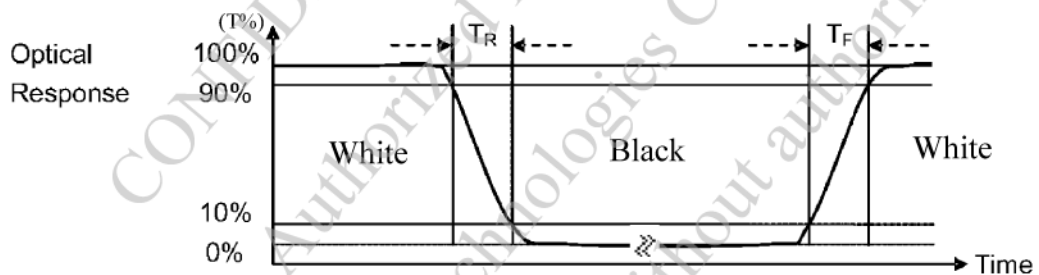

NOTE (5) : THE 100% TRANSMISSION IS DEFINED AS THE TRANSMISSION OF LCD PANEL WHEN ALL THE INPUT TERMINALS OF MODULE ARE ELECTRICALLY OPENED.

NOTE (6) : BRIGHTNESS MEASURED WHEN LCD IS AT "WHITE STATE"

6.2 THE TEST METHOD OF BRIGHTNESS AND UNIFORMITY

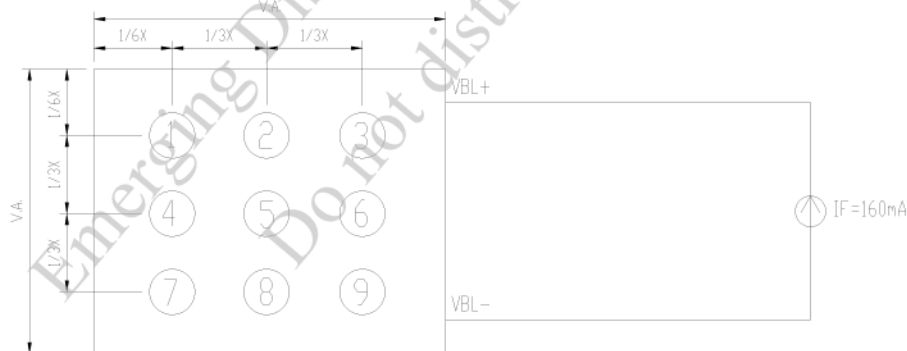

UNIT : mm

6.3 THE CALCULATING METHOD OF UNIFORMITY

$$\text{UNIFORMITY} = \left[1 - \frac{\text{MAXIMUM BRIGHTNESS} - \text{MINIMUM BRIGHTNESS}}{\text{AVERAGE BRIGHTNESS}} \right] \times 100\%$$

7. OUTLINE DIMENSIONS

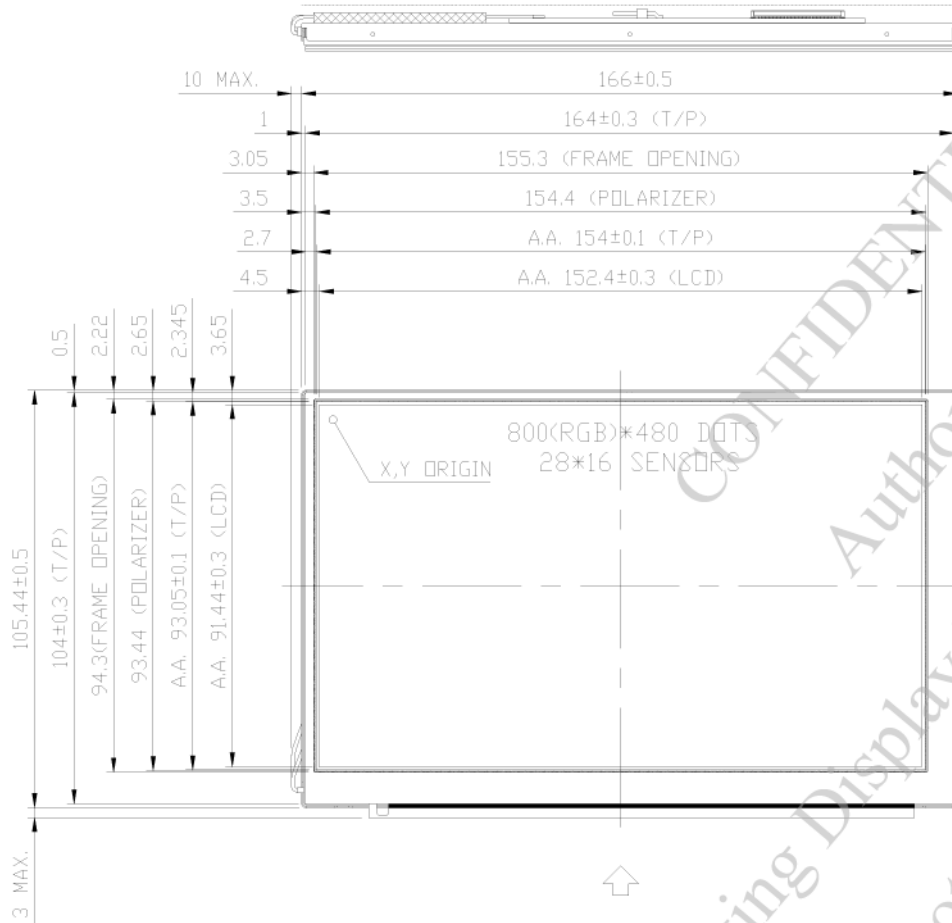

VIEWING DIRECTION

Best Contrast but with Gray Level Inversion

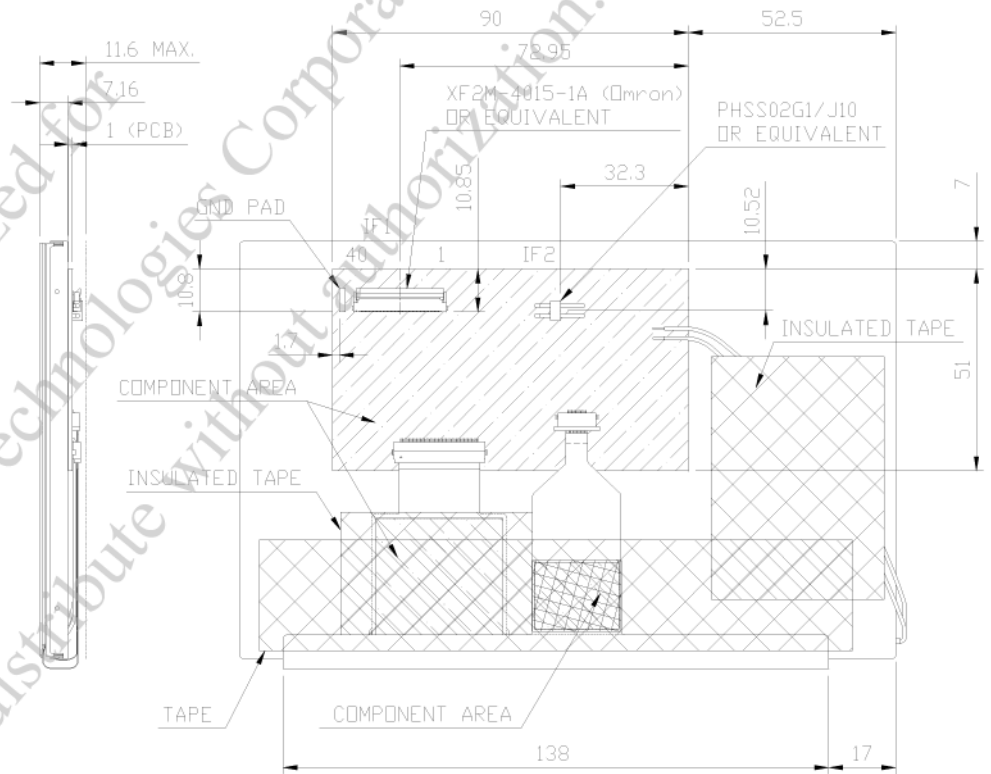

UNIT : mm

SCALE : NTS

NOT SPECIFIED TOLERANCE IS ± 0.5

NOTE : REAR BEZEL MATERIAL: SUS430 1D ANTI-GLARE

8. BLOCK DIAGRAM

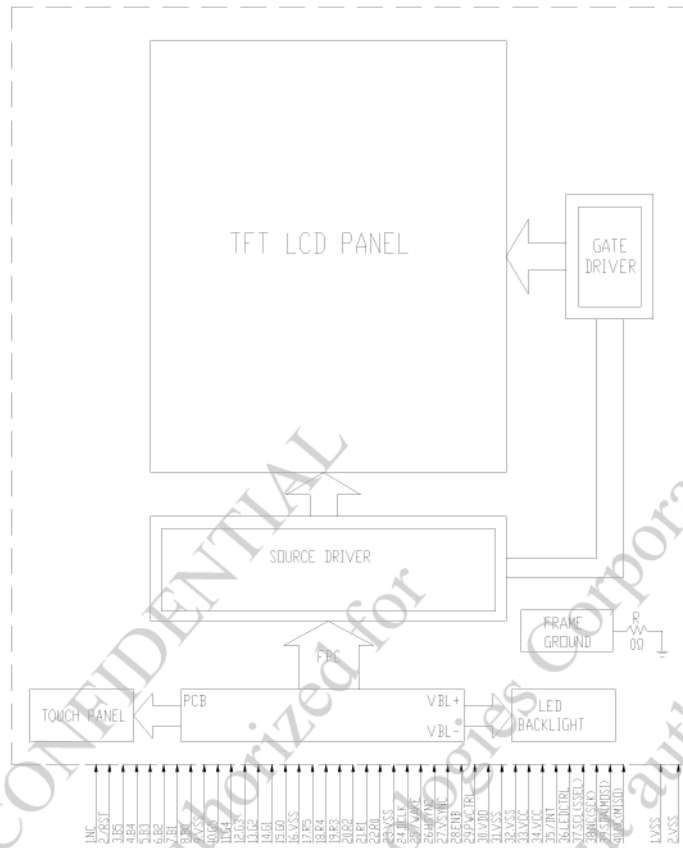

NOTE : UD = "H" LEVEL : OUT1→480 ; LR = "H" LEVEL : OUT1→800(DEFAULT)
 "L" LEVEL : OUT480→1 (DEFAULT) "L" LEVEL : OUT800→1

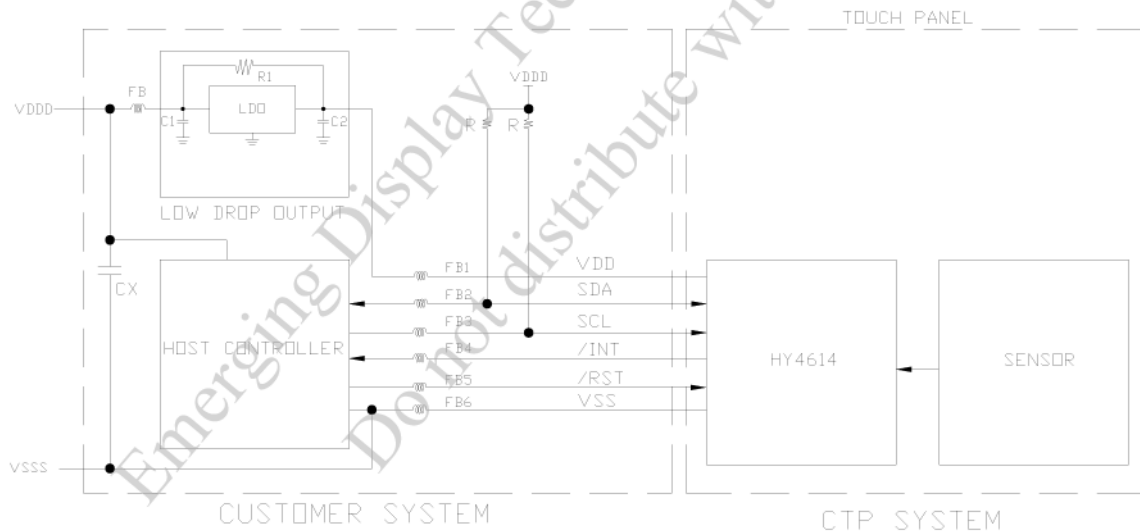

NOTE (1) : THE STANDARD IIC COMMUNICATION INTERFACE, SUPREME SCL CLOCK IS 400 KHz, SLAVE ADDRESS CAN BE SET UP, SUPPORTS VDD LEVEL POWER, NEEDS PULL HIGH RESISTANCE AND WE RECOMMEND THE PULL HIGH RESISTANCE IS 2.0K OHM.

NOTE (2) : POWER SUPPLY SHALL BE CLEAN AND NOISE FREE. ADDITIONAL FILTERING OR A SEPARATE LDO (LOW DROP OUT) REGULATOR CAN BE REQUIRED. C1 AND C2 CAPACITORS RECOMMENDATION : 4.7μF OR 10 μF

9. DETAIL DRAWING OF DOT MATRIX

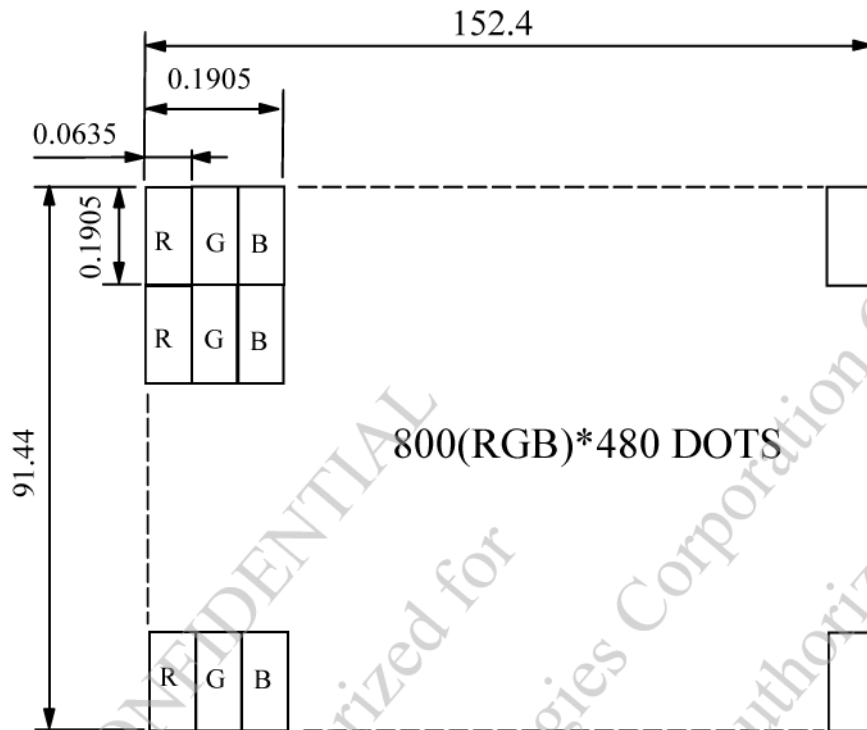

UNIT : mm
SCALE : NTS
NOT SPECIFIED TOLERANCE IS ± 0.1
DOTS MATRIX TOLERANCE IS ± 0.01

CONFIDENTIAL
Authorized for Emerging Display Technologies Corporation Only.
Do not distribute without authorization.

10. INTERFACE SIGNALS

10.1 IF1 :

PIN NO.	SYMBOL	I/O/P	FUNCTION	
1	NC	—	NON CONNECTION	
2	/RST	I	EXTERNAL RESET, LOW IS ACTIVE	TOUCH PANEL
3	B5	I	BLUE DATA BIT 5	
4	B4	I	BLUE DATA BIT 4	
5	B3	I	BLUE DATA BIT 3	
6	B2	I	BLUE DATA BIT 2	
7	B1	I	BLUE DATA BIT 1	
8	B0	I	BLUE DATA BIT 0	
9	VSS	P	GROUND (VSS IS CONNECTED TO METAL HOUSING WITH CONDUCTIVE TAPE)	
10	G5	I	GREEN DATA BIT 5	
11	G4	I	GREEN DATA BIT 4	
12	G3	I	GREEN DATA BIT 3	
13	G2	I	GREEN DATA BIT 2	
14	G1	I	GREEN DATA BIT 1	
15	G0	I	GREEN DATA BIT 0	
16	VSS	P	GROUND (VSS IS CONNECTED TO METAL HOUSING WITH CONDUCTIVE TAPE)	
17	R5	I	RED DATA BIT 5	
18	R4	I	RED DATA BIT 4	
19	R3	I	RED DATA BIT 3	
20	R2	I	RED DATA BIT 2	
21	R1	I	RED DATA BIT 1	
22	R0	I	RED DATA BIT 0	
23	VSS	P	GROUND (VSS IS CONNECTED TO METAL HOUSING WITH CONDUCTIVE TAPE)	
24	DCLK	I	DOT DATA CLOCK	
25	NC	—	NON CONNECTION	
26	HSYNC	I	HORIZONTAL SYNC INPUT. INTERNALLY PULL HIGH.	DE MODE : HSYNC, VSYNC CONNECTED TO VDD. SYNC MODE : ENB CONNECTED TO GROUND.
27	VSYNC	I	VERTICAL SYNC INPUT. INTERNALLY PULL HIGH.	
28	ENB	I	INPUT DATA ENABLE CONTROL. INTERNALLY PULLED LOW.	

PIN NO.	SYMBOL	I/O/P	FUNCTION		
29	PWCTRL	I		PWCTRL	REMARK
			LOGIC LEVEL H=3.3V L=0V	H	POWER ON
			L	SHUTDOWN	
30	VDD	P	POWER SUPPLY VOLTAGE		
31	VSS	P	GROUND (VSS IS CONNECTED TO METAL HOUSING WITH CONDUCTIVE TAPE)		
32	VSS	P	GROUND (VSS IS CONNECTED TO METAL HOUSING WITH CONDUCTIVE TAPE)		
33	VCC	P	POWER SUPPLY FOR LED DRIVER CIRCUIT		
34	VCC	P	POWER SUPPLY FOR LED DRIVER CIRCUIT		
35	/INT	O	EXTERNAL INTERRUPT TO THE HOST	TOUCH PANEL	
36	LEDCTRL	I	BRIGHTNESS CONTROL FOR LED BACKLIGHT		
37	SCL	I	I2C CLOCK INPUT	TOUCH PANEL	
38	NC	—	NON CONNECTION		
39	SDA	I/O	I2C DATA INPUT AND OUTPUT		
40	NC	—	NON CONNECTION		

10.2 IF2 :

PIN NO.	SYMBOL	I/O/P	FUNCTION
1	VSS	P	GROUND (VSS IS CONNECTED TO METAL HOUSING WITH CONDUCTIVE TAPE)
2	VSS	P	GROUND (VSS IS CONNECTED TO METAL HOUSING WITH CONDUCTIVE TAPE)

11. POWER SUPPLY

11.1 POWER SUPPLY FOR LCM

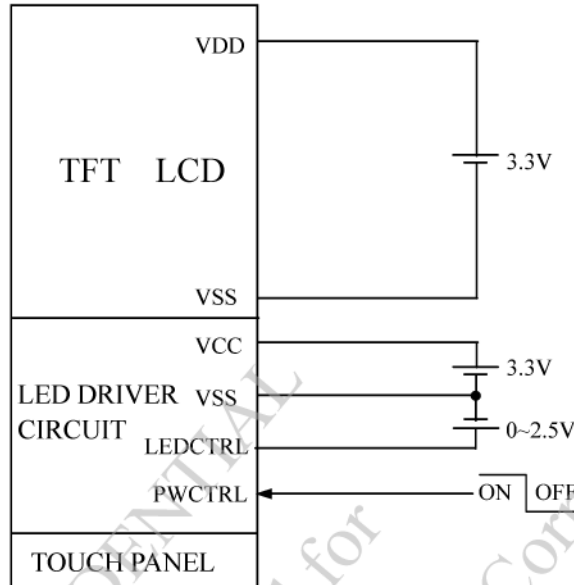

11.2 THE BRIGHTNESS CONTROLLED BY BACKLIGHT CURRENT OF LEDCTRL

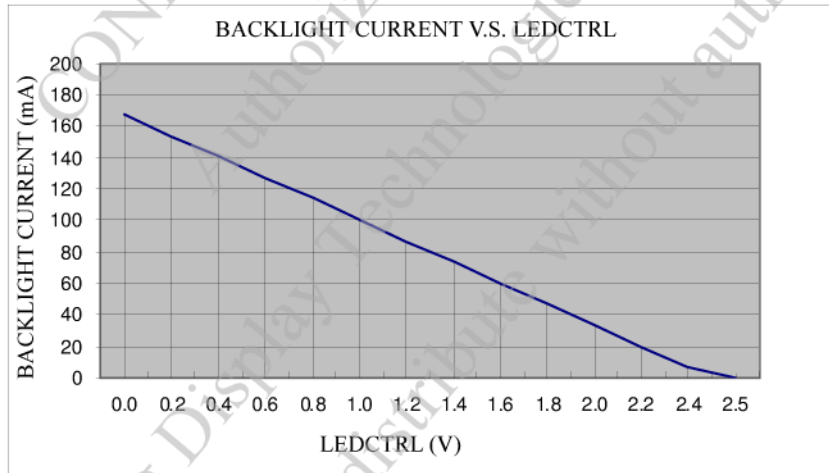

12. CAPACITIVE TOUCH PANEL SPECIFICATION

12.1 OPTICAL CHARACTERISTICS

ITEM	CONDITION	MIN.	TYP.	MAX.	UNIT
TRANSPARENCY NOTE (1)	Ta = 25°C	85	—	—	%

NOTE (1) : OPTICAL MEASUREMENT SHOULD BE EXECUTED AFTER PANEL IS SECURED. MEASUREMENT PROCESS SHOULD BE EXECUTED IN A STABLE, WINDLESS, AND DARK ROOM. OPTICAL SPECIFICATIONS SHOULD BE MEASURED BY SPECTROPHOTOMETER.

12.2 HARDNESS

ITEM	DESCRIPTION
SURFACE HARDNESS	7H (MIN.)

12.3 PROTOCOL

12.3.1 I2C READ

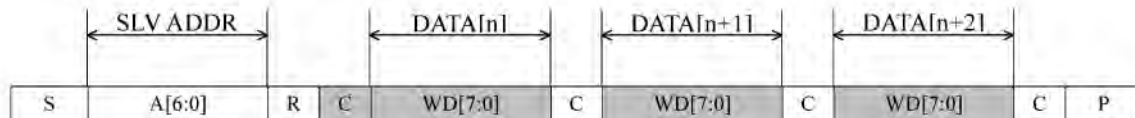

CHARACTER	DESCRIPTION
S	I2C START OR I2C RESTART
A[6:0]	SLAVE ADDRESS, THE VALUE CAN BE CUSTOMIZED
R	OPERATOR BYTE, SHOULD BE 1'b1. STANDS FOR READ
C	ACK SIGNAL
P	STOP SIGNAL (STOP SIGNAL IS OPTIONAL, RESTART SIGNAL IS ALSO OK FOR NEXT PACKET)

SLAVE ADDRESS=0x38

12.3.2 INTERRUPT SIGNAL FOR CTPM TO HOST

AS FOR STANDARD CTPM, HOST NEED TO USE BOTH INTERRUPT CONTROL SIGNAL AND SERIAL DATA INTERFACE TO GET THE TOUCH DATA.

HERE IS THE TIMING TO GET TOUCH DATA

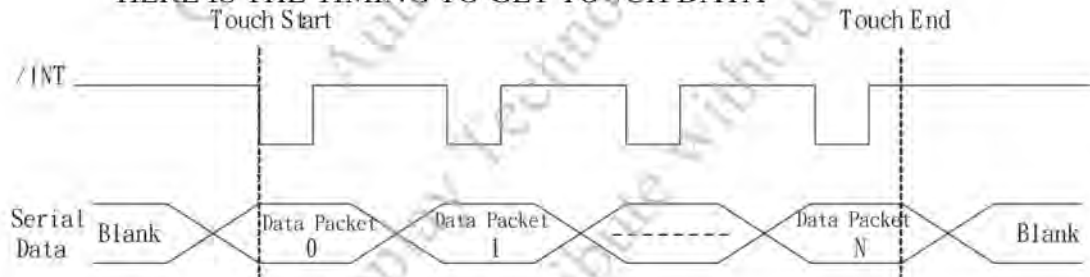

12.3.3 READ TOUCH DATA PACKET

WE DEFINED A CTPM PERIOD AS EACH CAPACITANCE DATA GATHERING AND DATA PROCESS, IN EACH CTPM, IF THERE IS A TOUCH DETECTS, THERE WILL WE A FAME OF TOUCH DATA. HOST CAN GET THE SPECIFIED FORMAT TOUCH DATA BY SERIAL DATA INTERFACE.

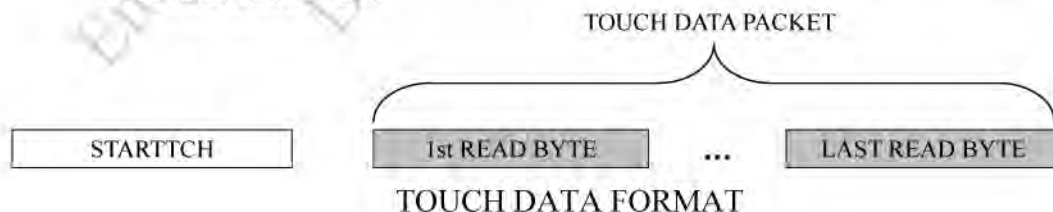

TOUCH DATA READ PROTOCOL

IN THIS MODE THE CTP IS FULLY FUNCTIONAL AS A TOUCH SCREEN CONTROLLER. READ AND WRITE ACCESS ADDRESS IS JUST LOGICAL ADDRESS WHICH IS NOT ENFORCED BY HARDWARE OR FIRMWARE. HERE IS THE OPERATING MODE REGISTER MAP.

ADDRESS	NAME	BIT7	BIT6	BIT5	BIT4	BIT3	BIT2	BIT1	BIT0	HOST ACCESS
02h	TD_STATUS					NUMBER OF TOUCH POINTS[3:0]				R
03h	TOUCH1_XH	1 st EVENT FLAG				1 st TOUCH X POSITION[11:8]				R
04h	TOUCH1_XL	1 st TOUCH X POSITION[7:0]								R
05h	TOUCH1_YH	1 st TOUCH ID[3:0]				1 st TOUCH Y POSITION[11:8]				R
06h	TOUCH1_YL	1 st TOUCH Y POSITION[7:0]								R
07h										
08h										
09h	TOUCH2_XH	2 nd EVENT FLAG				2 nd TOUCH X POSITION[11:8]				R
0Ah	TOUCH2_XL	2 nd TOUCH X POSITION[7:0]								R
0Bh	TOUCH2_YH	2 nd TOUCH ID[3:0]				2 nd TOUCH Y POSITION[11:8]				R
0Ch	TOUCH2_YL	2 nd TOUCH Y POSITION[7:0]								R
0Dh										R
0Eh										R
0Fh	TOUCH3_XH	3 rd EVENT FLAG				3 rd TOUCH X POSITION[11:8]				R
10h	TOUCH3_XL	3 rd TOUCH X POSITION[7:0]								R
11h	TOUCH3_YH	3 rd TOUCH ID[3:0]				3 rd TOUCH Y POSITION[11:8]				R
12h	TOUCH3_YL	3 rd TOUCH Y POSITION[7:0]								R
13h										R
14h										R
15h	TOUCH4_XH	4 th EVENT FLAG				4 th TOUCH X POSITION[11:8]				R
16h	TOUCH4_XL	4 th TOUCH X POSITION[7:0]								R
17h	TOUCH4_YH	4 th TOUCH ID[3:0]				4 th TOUCH Y POSITION[11:8]				R
18h	TOUCH4_YL	4 th TOUCH Y POSITION[7:0]								R
19h										R
1Ah										R
1Bh	TOUCH5_XH	5 th EVENT FLAG				5 th TOUCH X POSITION[11:8]				R
1Ch	TOUCH5_XL	5 th TOUCH X POSITION[7:0]								R
1Dh	TOUCH5_YH	5 th TOUCH ID[3:0]				5 th TOUCH Y POSITION[11:8]				R
1Eh	TOUCH5_YL	5 th TOUCH Y POSITION[7:0]								R
1Fh										R
20h										R
A6h	ID_G_FIRMID	FIRMWARE ID								R

TD_STATUS

THIS REGISTER IS THE TOUCH DATA STATUS REGISTER.

ADDRESS	BIT ADDRESS	REGISTER NAME	DESCRIPTION
02h	3:0	NUMBER OF TOUCH POINTS [3:0]	HOW MANY POINTS DETECTED. 1-5 IS VALID.
	7:4	NONE	NONE

TOUCHn_XH (n:1-5)

THIS REGISTER DESCRIBES MSB OF THE X COORDINATE OF THE NTH TOUCH POINT AND THE CORRESPONDING EVENT FLAG.

ADDRESS	BIT ADDRESS	REGISTER NAME	DESCRIPTION
03h ~ 1Bh	7:6	EVENT FLAG	00b: PUT DOWN 01b: PUT UP 10b: CONTACT 11b: RESERVED
	5:4	NONE	RESERVED
	3:0	TOUCH X POSITION [11:8]	MSB OF TOUCH X POSITION IN PIXELS

TOUCHn_XL (n:1-5)

THIS REGISTER DESCRIBES LSB OF THE X COORDINATE OF THE NTH TOUCH POINT.

ADDRESS	BIT ADDRESS	REGISTER NAME	DESCRIPTION
04h ~ 1Ch	7:0	TOUCH X POSITION [7:0]	LSB OF THE TOUCH X POSITION IN PIXELS

TOUCHn_YH (n:1-5)

THIS REGISTER DESCRIBES MSB OF THE Y COORDINATE OF THE NTH TOUCH POINT AND CORRESPONDING TOUCH ID.

ADDRESS	BIT ADDRESS	REGISTER NAME	DESCRIPTION
05h ~ 1Dh	7:4	TOUCH ID [3:0]	TOUCH ID OF TOUCH POINT
	3:0	TOUCH X POSITION [11:8]	MSB OF TOUCH Y POSITION IN PIXELS

TOUCHn_YL (n:1-5)

THIS REGISTER DESCRIBES LSB OF THE Y COORDINATE OF THE NTH TOUCH POINT.

ADDRESS	BIT ADDRESS	REGISTER NAME	DESCRIPTION
06h ~ 1Eh	7:0	TOUCH X POSITION [7:0]	LSB OF THE TOUCH Y POSITION IN PIXELS

ID_G_FIRMWARE_ID

THIS REGISTER DESCRIBES THE FIRMWARE ID OF THE APPLICATION

ADDRESS	BIT ADDRESS	REGISTER NAME	DESCRIPTION
A6h	7:0	ID_G_FIRMWARE_ID	FIRMWARE VERSION

12.4 INSPECTION STANDARDS

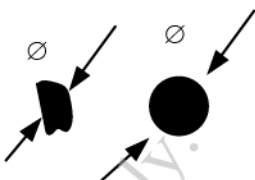
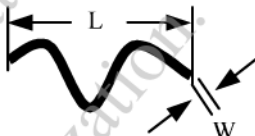
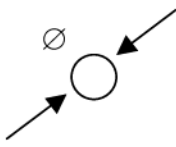
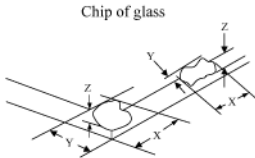
INSPECTION ITEMS	CRITERIA	REMARK										
BLACK/WHITE SPOT	THE FOLLOWING BLACK/WHITE SPOT ARE WITHIN THE VIEWING AREA. AVERAGE DIAMETER : D (mm)											
	<table border="1"> <thead> <tr> <th>SIZE D</th> <th>PERMISSIBLE NO.</th> </tr> </thead> <tbody> <tr> <td>$D \leq 0.1\text{mm}$</td> <td>IGNORE</td> </tr> <tr> <td>$0.1\text{mm} < D \leq 0.3\text{mm}$</td> <td>5</td> </tr> <tr> <td>$0.3\text{mm} < D \leq 0.5\text{mm}$</td> <td>5</td> </tr> <tr> <td>$D > 0.5\text{mm}$</td> <td>0</td> </tr> </tbody> </table>		SIZE D	PERMISSIBLE NO.	$D \leq 0.1\text{mm}$	IGNORE	$0.1\text{mm} < D \leq 0.3\text{mm}$	5	$0.3\text{mm} < D \leq 0.5\text{mm}$	5	$D > 0.5\text{mm}$	0
	SIZE D		PERMISSIBLE NO.									
	$D \leq 0.1\text{mm}$		IGNORE									
	$0.1\text{mm} < D \leq 0.3\text{mm}$		5									
$0.3\text{mm} < D \leq 0.5\text{mm}$	5											
$D > 0.5\text{mm}$	0											
NOTE (1) : THE DISTANCE BETWEEN DOT DEFECTS SHOULD BE MORE THAN 10mm APART.												
SCRATCH	THE FOLLOWING BLACK LINE, WHITE LINE IS WITHIN THE VIEWING AREA. WIDTH : W (mm) , LENGH : L (mm)											
	<table border="1"> <thead> <tr> <th>SIZE W & L</th> <th>PERMISSIBLE NO.</th> </tr> </thead> <tbody> <tr> <td>$W \leq 0.05\text{mm}$</td> <td>IGNORE</td> </tr> <tr> <td>$0.05\text{mm} < W \leq 0.07\text{mm}, L \leq 5\text{mm}$</td> <td>1</td> </tr> <tr> <td>$W > 0.07\text{mm}$</td> <td>0</td> </tr> </tbody> </table>		SIZE W & L	PERMISSIBLE NO.	$W \leq 0.05\text{mm}$	IGNORE	$0.05\text{mm} < W \leq 0.07\text{mm}, L \leq 5\text{mm}$	1	$W > 0.07\text{mm}$	0		
	SIZE W & L		PERMISSIBLE NO.									
	$W \leq 0.05\text{mm}$		IGNORE									
$0.05\text{mm} < W \leq 0.07\text{mm}, L \leq 5\text{mm}$	1											
$W > 0.07\text{mm}$	0											
LINEAR TYPE / FOREIGN FIBER	THE FOLLOWING BLACK LINE, WHITE LINE IS WITHIN THE VIEWING AREA. WIDTH : W (mm) , LENGH : L (mm)											
	<table border="1"> <thead> <tr> <th>SIZE W & L</th> <th>PERMISSIBLE NO.</th> </tr> </thead> <tbody> <tr> <td>$W \leq 0.05\text{mm}$</td> <td>IGNORE</td> </tr> <tr> <td>$0.05\text{mm} < W \leq 0.07\text{mm}, L \leq 5\text{mm}$</td> <td>1</td> </tr> <tr> <td>$W > 0.07\text{mm}$</td> <td>0</td> </tr> </tbody> </table>	SIZE W & L	PERMISSIBLE NO.	$W \leq 0.05\text{mm}$	IGNORE	$0.05\text{mm} < W \leq 0.07\text{mm}, L \leq 5\text{mm}$	1	$W > 0.07\text{mm}$	0			
	SIZE W & L	PERMISSIBLE NO.										
$W \leq 0.05\text{mm}$	IGNORE											
$0.05\text{mm} < W \leq 0.07\text{mm}, L \leq 5\text{mm}$	1											
$W > 0.07\text{mm}$	0											
BUBBLE / DENT	BUBBLES WITHIN VIEWING AREA. AVERAGE DIAMETER : D (mm)											
	<table border="1"> <thead> <tr> <th>SIZE D</th> <th>PERMISSIBLE NO.</th> </tr> </thead> <tbody> <tr> <td>$D \leq 0.2\text{mm}$</td> <td>IGNORE</td> </tr> <tr> <td>$0.2\text{mm} < D \leq 0.3\text{mm}$</td> <td>3</td> </tr> <tr> <td>$0.3\text{mm} < D \leq 0.5\text{mm}$</td> <td>1</td> </tr> <tr> <td>$D > 0.5\text{mm}$</td> <td>0</td> </tr> </tbody> </table>		SIZE D	PERMISSIBLE NO.	$D \leq 0.2\text{mm}$	IGNORE	$0.2\text{mm} < D \leq 0.3\text{mm}$	3	$0.3\text{mm} < D \leq 0.5\text{mm}$	1	$D > 0.5\text{mm}$	0
	SIZE D		PERMISSIBLE NO.									
	$D \leq 0.2\text{mm}$		IGNORE									
	$0.2\text{mm} < D \leq 0.3\text{mm}$		3									
$0.3\text{mm} < D \leq 0.5\text{mm}$	1											
$D > 0.5\text{mm}$	0											
NOTE (1) : THE DISTANCE BETWEEN DOT DEFECTS SHOULD BE MORE THAN 10mm APART.												
CHIP DAMAGE ON GLASS	<table border="1"> <tbody> <tr> <td>CORNER</td> <td>$X \leq 3\text{mm} \cdot Y \leq 3\text{mm} \cdot Z \leq t$ (t : THICKNESS)</td> </tr> <tr> <td>EDGE</td> <td>$X \leq 6\text{mm} \cdot Y \leq 1\text{mm} \cdot Z \leq t$ (t : THICKNESS)</td> </tr> </tbody> </table>	CORNER	$X \leq 3\text{mm} \cdot Y \leq 3\text{mm} \cdot Z \leq t$ (t : THICKNESS)	EDGE	$X \leq 6\text{mm} \cdot Y \leq 1\text{mm} \cdot Z \leq t$ (t : THICKNESS)							
	CORNER	$X \leq 3\text{mm} \cdot Y \leq 3\text{mm} \cdot Z \leq t$ (t : THICKNESS)										
EDGE	$X \leq 6\text{mm} \cdot Y \leq 1\text{mm} \cdot Z \leq t$ (t : THICKNESS)											

NOTE:

- 1.FOR ANY SPOTS OR LINES, WHICH ARE NOT OBSERVED UNDER APPROPRIATE PANEL OPERATING CONDITION ARE DEEMED ACCEPTABLE.
- 2.THE FOREIGN MATERIALS THAT CAN BE BLOWN OUT BY AIR AND REMOVED BY WET CLEANING ARE NOT REGARDED AS DEFECTS.

13. INSPECTION CRITERION

13.1 APPLICATION

THIS INSPECTION STANDARD IS TO BE APPLIED TO THE LCD MODULE DELIVERED FROM EMERGING DISPLAY TECHNOLOGIES CORP.(E.D.T) TO CUSTOMERS

13.2 INSPECTION CONDITIONS

13.2.1 (1)OBSERVATION DISTANCE : 35±5cm

(2)VIEW ANGLE :

NON-OPERATION CONDITION : ±5°
(PERPENDICULAR TO LCD PANEL SURFACE)

OPERATION CONDITION : ±45°
(PERPENDICULAR TO LCD PANEL SURFACE)

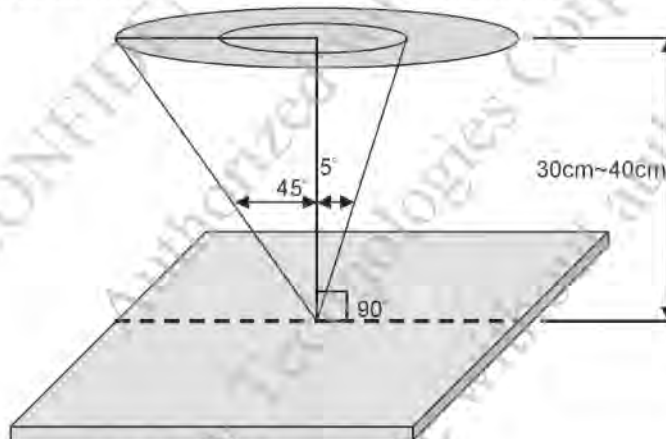

13.2.2 ENVIRONMENT CONDITIONS :

AMBIENT TEMPERATURE		25±5°C
AMBIENT HUMIDITY		65±20%RH
AMBIENT ILLUMINATION	COSMETIC INSPECTION	MORE THAN 600Lux
	FUNCTIONAL INSPECTION	300~500 Lux

13.2.3 INSPECTION LOT
QUANTITY PER DELIVERY LOT FOR EACH MODEL

13.2.4 INSPECTION METHOD
A SAMPLING INSPECTION SHALL BE MADE ACCORDING TO THE FOLLOWING PROVISIONS TO JUDGE THE ACCEPTABILITY

(a)APPLICABLE STANDARD : MIL-STD-105E
NORMAL INSPECTION, SINGLE SAMPLING
LEVEL II

(b)AQL : MAJOR DEFECT : AQL 0.65
MINOR DEFECT : AQL 1.0

13.3 INSPECTION STANDARDS

13.3.1 VISUAL DEFECTS CLASSIFICATION

TYPE OF DEFECT	INSPECTION ITEM	DEFECT FEATURE	AQL
MAJOR DEFECT	1.DISPLAY ON	<ul style="list-style-type: none"> • DEFECT TO MISS SPECIFIED DISPLAY FUNCTION, FOR ALL AND SPECIFIED DOTS EX: DISCONNECTION, SHORT CIRCUIT ETC 	0.65
	2.BACKLIGHT	<ul style="list-style-type: none"> • NO LIGHT • FLICKERING AND OTHER ABNORMAL ILLUMINATION 	
	3.DIMENSIONS	<ul style="list-style-type: none"> • SUBJECT TO INDIVIDUAL ACCEPTANCE SPECIFICATIONS 	
MINOR DEFECT	1.DISPLAY ZONE	<ul style="list-style-type: none"> • BLACK/WHITE SPOT • BUBBLES ON POLARIZER • NEWTON RING • BLACK/WHITE LINE • SCRATCH • CONTAMINATION • LEVER COLOR SPREED 	1.0
	2.BEZEL ZONE	<ul style="list-style-type: none"> • STAINS • SCRATCHES • FOREIGN MATTER 	
	3.SOLDERING	<ul style="list-style-type: none"> • INSUFFICIENT SOLDER • SOLDERED IN INCORRECT POSITION • CONVEX SOLDERING SPOT • SOLDER BALLS • SOLDER SCRAPS 	
	4.DISPLAY ON (ALL ON)	<ul style="list-style-type: none"> • LIGHT LINE 	

13.3.2 MODULE DEFECTS CLASSIFICATION

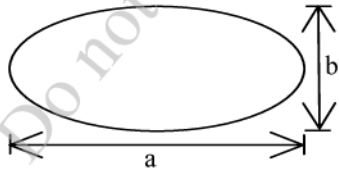
NO.	ITEM	CRITERIA												
1	DISPLAY ON INSPECTION	(1)INCORRECT PATTERN (2)MISSING SEGMENT (3)DIM SEGMENT (4)OPERATING VOLTAGE BEYOND SPEC												
2	OVERALL DIMENSIONS	(1)OVERALL DIMENSION BEYOND SPEC												
3	DOT DEFECT	(1)INSPECTION PATTERN: FULL WHITE, FULL BLACK, RED, GREEN AND BLUE SCREENS. (2) <table border="1" style="margin-left: 20px;"> <thead> <tr> <th>ITEMS</th> <th>ACCEPTABLE COUNT</th> </tr> </thead> <tbody> <tr> <td>BRIGHT DOT</td> <td>$N \leq 4$</td> </tr> <tr> <td>DARK DOT</td> <td>$N \leq 5$</td> </tr> <tr> <td>TOTAL BRIGHT AND DARK DOTS</td> <td>$N \leq 5$</td> </tr> </tbody> </table> <p>NOTE :</p> <p>1. THE DEFINITION OF DOT : THE SIZE OF A DEFECTIVE DOT OVER 1/2 OF WHOLE DOT IS REGARDED AS ONE DEFECTIVE DOT.</p> <p>2. BRIGHT DOT : DOTS APPEAR BRIGHT AND UNCHANGED IN SIZE IN WHICH LCD PANEL IS DISPLAYING UNDER BLACK PATTERN.</p> <p>3. DARK DOT : DOTS APPEAR DARK AND UNCHANGED IN SIZE IN WHICH LCD PANEL IS DISPLAYING UNDER PURE RED, GREEN, BLUE PICTURE.</p>	ITEMS	ACCEPTABLE COUNT	BRIGHT DOT	$N \leq 4$	DARK DOT	$N \leq 5$	TOTAL BRIGHT AND DARK DOTS	$N \leq 5$				
ITEMS	ACCEPTABLE COUNT													
BRIGHT DOT	$N \leq 4$													
DARK DOT	$N \leq 5$													
TOTAL BRIGHT AND DARK DOTS	$N \leq 5$													
4	FOREIGN BLACK/WHITE/ BRIGHT LINE/ SCRATCH OF VIEWING AREA	<table border="1" style="margin-left: 20px;"> <thead> <tr> <th>LENGTH : L</th> <th>WIDTH : W</th> <th>PERMISSIBLE NO.</th> </tr> </thead> <tbody> <tr> <td>$L \leq 0.3$</td> <td>$W \leq 0.05$</td> <td>IGNORE</td> </tr> <tr> <td>$0.3 < L \leq 2.5$</td> <td>$0.05 < W \leq 0.1$</td> <td>4</td> </tr> <tr> <td>$2.5 < L$</td> <td>$0.1 < W$</td> <td>NONE</td> </tr> </tbody> </table> <p>WIDTH : W mm, LENGTH : L mm</p>	LENGTH : L	WIDTH : W	PERMISSIBLE NO.	$L \leq 0.3$	$W \leq 0.05$	IGNORE	$0.3 < L \leq 2.5$	$0.05 < W \leq 0.1$	4	$2.5 < L$	$0.1 < W$	NONE
LENGTH : L	WIDTH : W	PERMISSIBLE NO.												
$L \leq 0.3$	$W \leq 0.05$	IGNORE												
$0.3 < L \leq 2.5$	$0.05 < W \leq 0.1$	4												
$2.5 < L$	$0.1 < W$	NONE												
5	FOREIGN MATTER \ BLACK SPOTS \ WHITE SPOTS \ DENT (INCLUDING LIGHT LEAKAGE DUE TO POLARIZING PLATES PINHOLES, ETC.)	<table border="1" style="margin-left: 20px;"> <thead> <tr> <th>AVERAGE DIAMETER (mm): D</th> <th>NUMBER OF PIECES PERMITTED</th> </tr> </thead> <tbody> <tr> <td>$D \leq 0.15$</td> <td>IGNORE</td> </tr> <tr> <td>$0.15 < D \leq 0.5$</td> <td>4</td> </tr> <tr> <td>$0.5 < D$</td> <td>NONE</td> </tr> </tbody> </table> <p>NOTE : DIAMETER $D=(a+b)/2$</p> 	AVERAGE DIAMETER (mm): D	NUMBER OF PIECES PERMITTED	$D \leq 0.15$	IGNORE	$0.15 < D \leq 0.5$	4	$0.5 < D$	NONE				
AVERAGE DIAMETER (mm): D	NUMBER OF PIECES PERMITTED													
$D \leq 0.15$	IGNORE													
$0.15 < D \leq 0.5$	4													
$0.5 < D$	NONE													

NO.	ITEM	CRITERIA		
			AVERAGE DIAMETER (mm) : D	NUMBER OF PIECES PERMITTED
6	BUBBLES OF POLARIZER /DIRT/CF FAIL /SURFACE STAINS	BUBBLE ON THE POLARIZER	$D \leq 0.25$	IGNORE
			$0.25 < D \leq 0.5$	$N \leq 5$
			$0.5 < D$	NONE
		SURFACE STAINS	$D < 0.1$	IGNORE
			$0.1 < D \leq 0.3$	$N \leq 3$
		CF FAIL / SPOT	$D < 0.1$	IGNORE
		$0.1 < D \leq 0.3$	$N \leq 3$	
		<p>NOTE : (1)POLARIZER BUBBLE IS DEFINED AS THE BUBBLE APPEARS ON ACTIVE DISPLAY AREA. THE DEFECT OF POLARIZER BUBBLE SHALL BE IGNORED IF THE POLARIZER BUBBLE APPEARS ON THE OUTSIDE OF ACTIVE DISPLAY AREA.</p> <p>(2)THE EXTRANEIOUS SUBSTANCE IS DEFINED AS IT CAN BE OBSERVED WHEN THE MODULE IS POWER ON.</p> <p>(3)THE DEFINITION OF AVERAGE DIAMETER, D IS DEFINED AS FOLLOWING.</p> <p>AVERAGE DIAMETER (D)=(a+b)/2</p> 		
7	LINE DEFECT ON DISPLAY	OBVIOUS VERTICAL OR HORIZONTAL LINE DEFECT IS NOT ALLOWED		
8	MURA ON DISPLAY	IT'S OK IF MURA IS SLIGHT VISIBLE THROUGH 6% ND FILTER		
9	UNEVEN COLOR SPREAD, COLORATION	(1)TO BE DETERMINED BASED UPON THE STANDARD SAMPLE.		
10	BEZEL APPEARANCE	(1)BEZEL MAY NOT HAVE RUST, BE DEFORMED OR HAVE FINGER PRINTS STAINS OF OTHER CONTAMINATION. (2)BEZEL MUST COMPLY WITH JOB SPECIFICATIONS.		
11	PCB	<p>(1)THERE MAY NOT BE MORE THAN 2mm OF SEALANT OUTSIDE THE SEAL AREA ON THE PCB, AND THERE SHOULD BE NO MORE THAN THREE PLACES.</p> <p>(2)NO OXIDATION OR CONTAMINATION PCB TERMINALS.</p> <p>(3)PARTS ON PCB MUST BE THE SAME AS ON THE PRODUCTION CHARACTERISTIC CHART. THERE SHOULD BE NO WRONG PARTS, MISSING PARTS OR EXCESS PARTS.</p> <p>(4)THE JUMPER ON THE PCB SHOULD CONFORM TO THE PRODUCT CHARACTERISTIC CHART.</p> <p>(5)IF SOLDER GETS ON BEZEL TAB PADS, LED PAD, ZEBRA PAD OR SCREW HOLD PAD; MAKE SURE IT IS SMOOTHED DOWN.</p>		

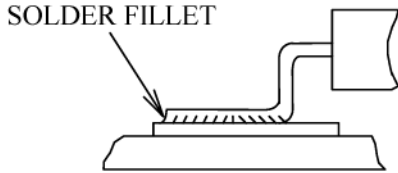
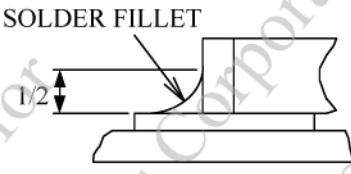
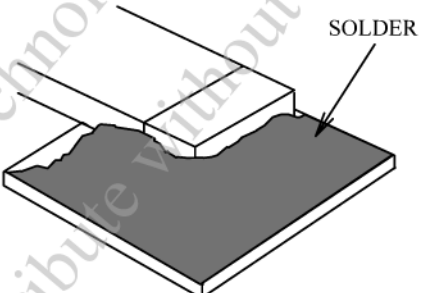
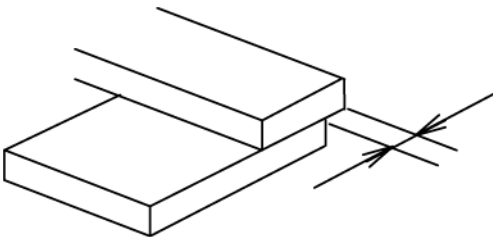
NO.	ITEM	CRITERIA
12	SOLDERING	<p>(1) NO SOLDERING FOUND ON THE SPECIFIED PLACE</p> <p>(2) INSUFFICIENT SOLDER</p> <p>(a) LSI, IC A POOR WETTING OF SOLDER IS BETWEEN LOWER BEND OR "HEEL" OF LEAD AND PAD</p>  <p>(b) CHIP COMPONENT</p> <ul style="list-style-type: none"> SOLDER IS LESS THAN 50% OF SIDES AND FRONT FACE WETTING  <ul style="list-style-type: none"> SOLDER WETS 3 SIDES OF TERMINAL, BUT LESS THAN 25% OF SIDES AND FRONT SURFACE AREA ARE COVERED  <p>(3) PARTS ALIGNMENT</p> <p>(a) LSI, IC LEAD WIDTH IS MORE THAN 50% BEYOND PAD OUTLINE</p> 

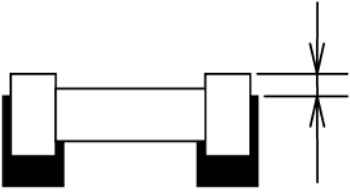
NO.	ITEM	CRITERIA
12	SOLDERING	<p>(b)CHIP COMPONENT COMPONENT IS OFF CENTER, AND MORE THAN 50% OF THE LEADS IS OFF THE PAD OUTLINE</p>  <p>(4)NO UNMELTED SOLDER PASTE MAY BE PRESENT ON THE PCB. (5)NO COLD SOLDER JOINTS, MISSING SOLDER CONNECTIONS, OXIDATION OR ICICLE. (6)NO RESIDUE OR SOLDER BALLS ON PCB. (7)NO SHORT CIRCUITS IN COMPONENTS ON PCB.</p>
13	BACKLIGHT	<p>(1)NO LIGHT (2)FLICKERING AND OTHER ABNORMAL ILLUMINATION (3)SPOTS OR SCRATCHES THAT APPEAR WHEN LIT MUST BE JUDGED USING LCD SPOT, LINES AND CONTAMINATION STANDARDS. (4)BACKLIGHT DOESN'T LIGHT OR COLOR IS WRONG.</p>
14	GENERAL APPEARANCE	<p>(1)NO OXIDATION, CONTAMINATION, CURVES OR, BENDS ON INTERFACE PIN (OLB) OF TCP. (2)NO CRACKS ON INTERFACE PIN (OLB) OF TCP. (3)NO CONTAMINATION, SOLDER RESIDUE OR SOLDER BALLS ON PRODUCT. (4)THE IC ON THE TCP MAY NOT BE DAMAGED, CIRCUITS. (5)THE UPPERMOST EDGE OF THE PROTECTIVE STRIP ON THE INTERFACE PIN MUST BE PRESENT OR LOOK AS IF IT CAUSE THE INTERFACE PIN TO SEVER. (6)THE RESIDUAL ROSIN OR TIN OIL OF SOLDERING (COMPONENT OR CHIP COMPONENT) IS NOT BURNED INTO BROWN OR BLACK COLOR. (7)SEALANT ON TOP OF THE ITO CIRCUIT HAS NOT HARDENED. (8)PIN TYPE MUST MATCH TYPE IN SPECIFICATION SHEET. (9)LCD PIN LOOSE OR MISSING PINS. (10)PRODUCT PACKAGING MUST THE SAME AS SPECIFIED ON PACKAGING SPECIFICATION SHEET. (11)PRODUCT DIMENSION AND STRUCTURE MUST CONFORM TO PRODUCT SPECIFICATION SHEET. (12)THE APPEARANCE OF HEAT SEAL SHOULD NOT ADMIT ANY DIRT AND BREAK.</p>

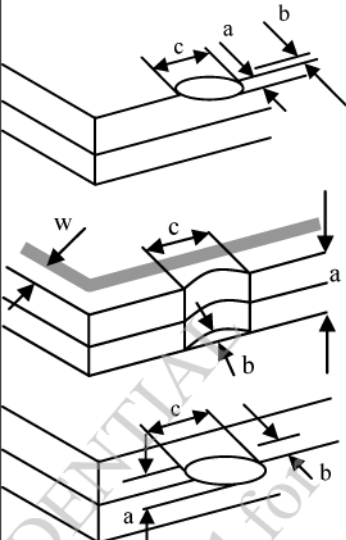
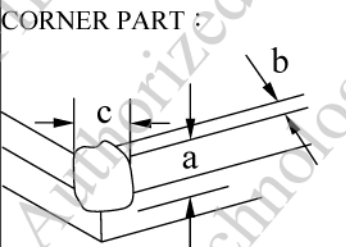
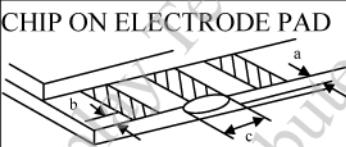
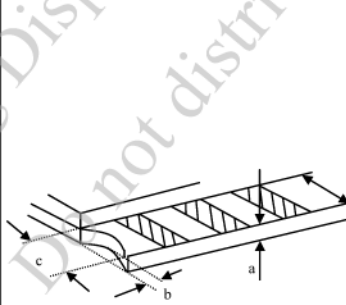
NO.	ITEM	CRITERIA									
15	CRACKED GLASS	<p>THE LCD WITH EXTENSIVE CRACK IS NOT ACCEPTABLE</p> <p>GENERAL GLASS CHIP :</p>  <table border="1"> <thead> <tr> <th>a</th> <th>b</th> <th>c</th> </tr> </thead> <tbody> <tr> <td>$\leq t/2$</td> <td>< VIEWING AREA</td> <td>$\leq 1/8X$</td> </tr> <tr> <td>$t/2 > , \leq 2t$</td> <td>$\leq W/2$</td> <td>$\leq 1/8X$</td> </tr> </tbody> </table> <p>*W=DISTANCE BETWEEN SEALANT AREA AND LCD PANEL EDGE X = LCD SIDE LENGTH t = GLASS THICKNESS</p>	a	b	c	$\leq t/2$	< VIEWING AREA	$\leq 1/8X$	$t/2 > , \leq 2t$	$\leq W/2$	$\leq 1/8X$
		a	b	c							
		$\leq t/2$	< VIEWING AREA	$\leq 1/8X$							
		$t/2 > , \leq 2t$	$\leq W/2$	$\leq 1/8X$							
		<p>CORNER PART :</p>  <table border="1"> <thead> <tr> <th>a</th> <th>b</th> <th>c</th> </tr> </thead> <tbody> <tr> <td>$\leq t/2$</td> <td>< VIEWING AREA</td> <td>$\leq 1/8X$</td> </tr> <tr> <td>$> t/2 , \leq 2t$</td> <td>$\leq W/2$</td> <td>$\leq 1/8X$</td> </tr> </tbody> </table> <p>*W=DISTANCE BETWEEN SEALANT AREA AND LCD PANEL EDGE X = LCD SIDE LENGTH t = GLASS THICKNESS</p>	a	b	c	$\leq t/2$	< VIEWING AREA	$\leq 1/8X$	$> t/2 , \leq 2t$	$\leq W/2$	$\leq 1/8X$
a	b	c									
$\leq t/2$	< VIEWING AREA	$\leq 1/8X$									
$> t/2 , \leq 2t$	$\leq W/2$	$\leq 1/8X$									
<p>CHIP ON ELECTRODE PAD</p>  <table border="1"> <thead> <tr> <th>a</th> <th>b</th> <th>c</th> </tr> </thead> <tbody> <tr> <td>$\leq t$</td> <td>$\leq 0.5\text{mm}$</td> <td>$\leq 1/8X$</td> </tr> </tbody> </table> <p>*X=LCD SIDE WIDTH t=GLASS THICKNESS</p>	a	b	c	$\leq t$	$\leq 0.5\text{mm}$	$\leq 1/8X$					
a	b	c									
$\leq t$	$\leq 0.5\text{mm}$	$\leq 1/8X$									
 <table border="1"> <thead> <tr> <th>a</th> <th>b</th> <th>c</th> </tr> </thead> <tbody> <tr> <td>$\leq t$</td> <td>$\leq 1/8X$</td> <td>$\leq L$</td> </tr> </tbody> </table> <p>*X=LCD SIDE WIDTH t = GLASS THICKNESS L=ELECTRODE PAD LENGTH</p> <p>①IF GLASS CHIPPING THE ITO TERMINAL, OVER 2/3 OF THE ITO MUST REMAIN AND BE, INSPECTED ACCORDING TO ELECTRODE TERMINAL SPECIFICATIONS</p> <p>②IF THE PRODUCT WILL BE HEAT SEALED BY THE CUSTOMER, THE ALIGNMENT MARK MUST NOT BE DAMAGED</p>	a	b	c	$\leq t$	$\leq 1/8X$	$\leq L$					
a	b	c									
$\leq t$	$\leq 1/8X$	$\leq L$									

13.4 RELIABILITY TEST

13.4.1 STANDARD SPECIFICATIONS FOR RELIABILITY OF LCD MODULE

NO.	ITEM	DESCRIPTION
1	HIGH TEMPERATURE OPERATION	THE SAMPLE SHOULD BE ALLOWED TO STAND AT +70°C FOR 240 HRS
2	LOW TEMPERATURE OPERATION	THE SAMPLE SHOULD BE ALLOWED TO STAND AT -20°C FOR 240 HRS
3	HIGH TEMPERATURE STORAGE	THE SAMPLE SHOULD BE ALLOWED TO STAND AT +80°C FOR 240 HRS
4	LOW TEMPERATURE STORAGE	THE SAMPLE SHOULD BE ALLOWED TO STAND AT -30°C FOR 240 HRS
5	HIGH TEMPERATURE /HUMIDITY TEST STORAGE	THE SAMPLE SHOULD BE ALLOWED TO STAND AT 60°C, 90% RH 240 HRS
6	THERMAL SHOCK (NOT OPERATED)	<p>THE SAMPLE SHOULD BE ALLOWED TO STAND THE FOLLOWING 10 CYCLES OF OPERATION:</p>
7	ESD (ELECTROSTATIC DISCHARGE) (NOT OPERATED)	AIR DISCHARGE ± 12KV CONTACT DISCHARGE ± 8KV (ACCORDING TO IEC-61000-4-2)

NOTE (1) : THE TEST SAMPLES HAVE RECOVERY TIME FOR 2 HOURS AT ROOM TEMPERATURE BEFORE THE FUNCTION CHECK. IN THE STANDARD CONDITIONS, THERE IS NO DISPLAY FUNCTION NG ISSUE OCCURRED.

13.5 TESTING CONDITIONS AND INSPECTION CRITERIA

FOR THE FINAL TEST THE TESTING SAMPLE MUST BE STORED AT ROOM TEMPERATURE FOR 24 HOURS, AFTER THE TESTS LISTED IN TABLE 13.5, STANDARD SPECIFICATIONS FOR RELIABILITY HAVE BEEN EXECUTED IN ORDER TO ENSURE STABILITY.

NO.	ITEM	TEST MODEL	INSPECTION CRITERIA
1	CURRENT CONSUMPTION	REFER TO SPECIFICATION	THE CURRENT CONSUMPTION SHOULD CONFORM TO THE PRODUCT SPECIFICATION.
2	CONTRAST	REFER TO SPECIFICATION	AFTER THE TESTS HAVE BEEN EXECUTED, THE CONTRAST MUST BE LARGER THAN HALF OF ITS INITIAL VALUE PRIOR TO THE TESTS.
3	APPEARANCE	VISUAL INSPECTION	DEFECT FREE

13.6 OPERATION

- 13.6.1 DO NOT CONNECT OR DISCONNECT MODULES TO OR FROM THE MAIN SYSTEM WHILE POWER IS BEING SUPPLIED .
- 13.6.2 USE THE MODULE WITHIN SPECIFIED TEMPERATURE ; LOWER TEMPERATURE CAUSES THE RETARDATION OF BLINKING SPEED OF THE DISPLAY ; HIGHER TEMPERATURE MAKES OVERALL DISPLAY DISCOLOR . WHEN THE TEMPERATURE RETURNS TO NORMALITY, THE DISPLAY WILL OPERATE NORMALLY.
- 13.6.3 ADJUST THE LC DRIVING VOLTAGE TO OBTAIN THE OPTIMUM CONTRAST .
- 13.6.4 POWER ON SEQUENCE INPUT SIGNALS SHOULD NOT BE SUPPLIED TO LCD MODULE BEFORE POWER SUPPLY VOLTAGE IS APPLIED AND REACHES THE SPECIFIED VALUE.
IF ABOVE SEQUENCE IS NOT FOLLOWED , CMOS LSIS OF LCD MODULES MAY BE DAMAGED DUE TO LATCH - UP PROBLEM.
- 13.6.5 NOT ALLOWED TO INFLICT ANY EXTERNAL STRESS AND TO CAUSE ANY MECHANICAL INTERFERENCE ON THE BENDING AREA OF FPC DURING THE TAIL BENDING BACKWARDS!
DO NOT STRESS FPC AND IC ON THE MODULE!

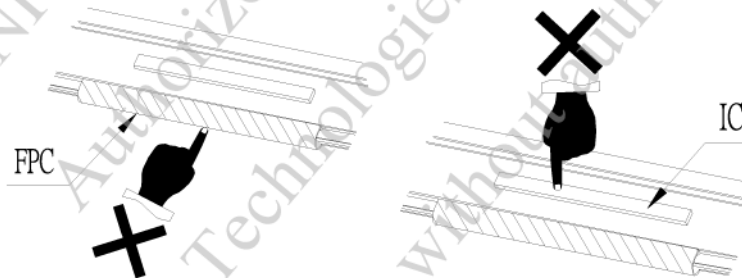

13.7 NOTICE

- 13.7.1 USE A GROUNDED SOLDERING IRON WHEN SOLDERING CONNECTOR I/O TERMINALS . FOR SOLDERING OR REPAIRING, TAKE PRECAUTION AGAINST THE TEMPERATURE OF THE SOLDERING IRON AND THE SOLDERING TIME TO PREVENT PEELING OFF THE THROUGH-HOLE-PAD .
- 13.7.2 DO NOT DISASSEMBLE . EDT SHALL NOT BE HELD RESPONSIBLE IF THE MODULE IS DISASSEMBLED AND UPON THE REASSEMBLY THE MODULE FAILED.
- 13.7.3 DO NOT CHARGE STATIC ELECTRICITY, AS THE CIRCUIT OF THIS MODULE CONTAINS CMOS LSIS. A WORKMAN'S BODY SHOULD ALWAYS BE STATIC-PROTECTED BY USE OF AN ESD STRAP. WORKING CLOTHES FOR SUCH PERSONNEL SHOULD BE OF STATIC-PROTECTED MATERIAL.
- 13.7.4 ALWAYS GROUND THE ELECTRICALLY-POWERED DRIVER BEFORE USING IT TO INSTALL THE LCD MODULE. WHILE CLEANING THE WORK STATION BY VACUUM CLEANER, DO NOT BRING THE SUCKING MOUTH NEAR THE MODULE ; STATIC ELECTRICITY OF THE ELECTRICALLY-POWERED DRIVER OR THE VACUUM CLEANER MAY DESTROY THE MODULE.
- 13.7.5 DON'T GIVE EXTERNAL SHOCK.
- 13.7.6 DON'T APPLY EXCESSIVE FORCE ON THE SURFACE.
- 13.7.7 LIQUID IN LCD IS HAZARDOUS SUBSTANCE. MUST NOT LICK AND SWALLOW.
WHEN THE LIQUID IS ATTACHED TO YOUR, SKIN, CLOTH ETC. WASH IT OUT THOROUGHLY AND IMMEDIATELY.
- 13.7.8 DON'T OPERATE IT ABOVE THE ABSOLUTE MAXIMUM RATING.
- 13.7.9 STORAGE IN A CLEAN ENVIRONMENT, FREE FROM DUST, ACTIVE GAS AND SOLVENT.
- 13.7.10 STORE WITHOUT ANY PHYSICAL LOAD.
- 13.7.11 REWIRING: NO MORE THAN 3 TIMES.