

# NXH3675: ULTRA-LOW POWER BLUETOOTH® LOW ENERGY AUDIO SOLUTION

The NXH3675 is Bluetooth 5.3 LE audio certified and supports Auracast™. It enables multi-stream audio, including broadcast, and supports HQ audio (TMAP) and other standard audio profiles. The NXH3675 is a highly efficient chip designed to function with minimum power consumption and optimized for ultra-low latency applications, ideally suited for wireless audio applications, such as gaming headsets, wireless speakers, microphones, conference speakerphones and hearables. Due to the integrated ultra-low power radio and ultra-low power DSP processing capabilities, the NXH3675 provides exceptionally long battery life and the opportunity to build miniaturized small form-factor products.

## KEY FEATURES

- Bluetooth 5.3 LE audio certified with Auracast™ in the 2.4 GHz radio band
- A Cortex®-M0+ for application control and Bluetooth Low Energy host stack
- A dedicated Cortex-M0+ for supporting full flexible software link-layer protocol up to the HCI level
- A dual CoolFlux® DSP for audio processing of the LC3 and LC3+ audio encoder/decoder and audio & voice enhancements such as EQ, compression, gain control and mixing
- A low-power 16 MHz/32 MHz crystal oscillator with integrated tuning caps and automatic frequency selection
- Support for two digital PDM-based microphones
- Improves battery life – exceptionally low power consumption
- Includes NXP's proprietary protocol for ultra-low latency ~20 ms

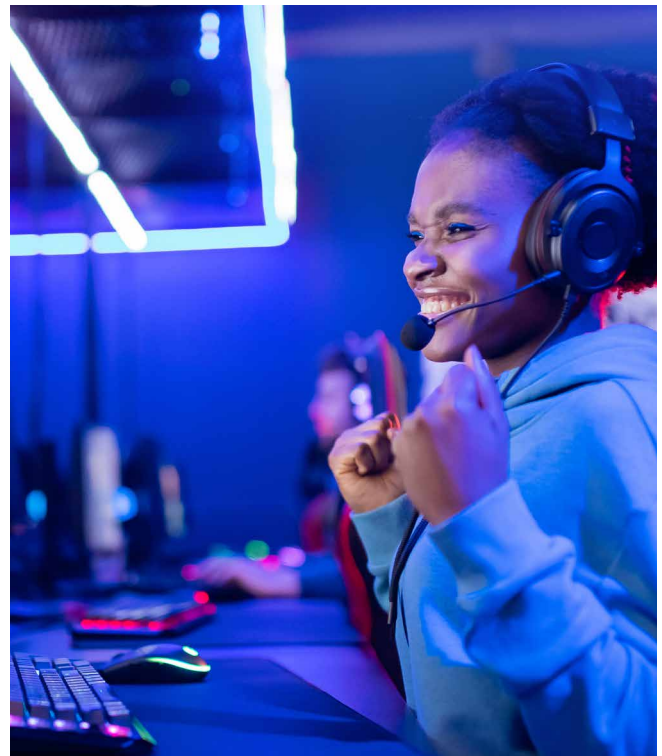

## APPLICATIONS

- Gaming headphones
- Wireless speakers
- Soundbars & TV transmitters
- Wireless headphones and earbuds
- Communication headsets & conferencing phones
- Hearing aids
- Wireless microphones

## BLUETOOTH 5.3 LE AUDIO STANDARD

NXP has been a forefront technology player in Bluetooth Audio and now one of the essential members of the latest Bluetooth 5.3 LE audio standardization. The NXH3675 complies with the new LE Audio standard supporting LC3 codec that allows streaming of HQ audio under low power consumption with low latency and Auracast, a broadcast audio communication, enabling novel audio sharing use cases.

## PLATFORM CAPABILITIES

NXH3675 houses a dual CoolFlux DSP subsystem and extended memory resources supporting

- LE Audio compliant LC3 and LC3 PLC audio streaming, 48 kHz sample rate
- LC3+ audio channels, 48 kHz and 96 kHz sample rate
- Up to 7 simultaneous audio streams in flexible unicast audio topologies
- Optimized for ultra-low latency operation

## TYPICAL APPLICATION: GAMING HEADSET - PROPRIETARY AUDIO STREAMING PROTOCOL

The NXH3675 device runs the standard LE Audio profile and NXP's proprietary gaming profile simultaneously. As a result, it supports

- Forward audio path
  - Stereo
  - 48 kHz sampling rate, 24 bit resolution
  - Audio BW > 20 kHz
  - LC3+ codec
  - Latency ~20 ms

- Simultaneous return audio path
  - Mono
  - 32 kHz sampling rate, 24 bit resolution
  - Audio BW > 13 kHz
  - LC3+ codec
- A simultaneous, bi-directional audio streaming and data connection with a mobile phone while the gaming headset is actively involved during gaming

The total power consumption of the headphone is only 20 mW during audio streaming, which is exceptionally low for an advanced gaming headset use case.

## STARTER KIT

To simplify development and reduce time-to-market, NXP offers a NXH3675 starter kit which includes

- NXH3675 Evaluation kit – For debug and evaluation purposes
  - LPC55 host microcontroller
  - Audio codec supporting A-to-D and D-to-A conversion

- Connectors for the LPC55 serial wire debug interface
- Micro USB connector for audio interface and recharging Li-ion battery
- Peripherals for the user interface: buttons, switches
- Battery-powered operation
- NXH3675 Application Kit – Form factor Headset
- NXH3675 Application Kit – Form factor Dongle (Available in Q1 2023)
- Software Development Kit includes
  - Drivers, operating system, middleware and LE audio host stack
  - Application reference code for gaming headset
  - MCUXpresso IDE
  - Tool suite for configuration and radio test

## NXH3675 BLOCK DIAGRAM — HEADSET

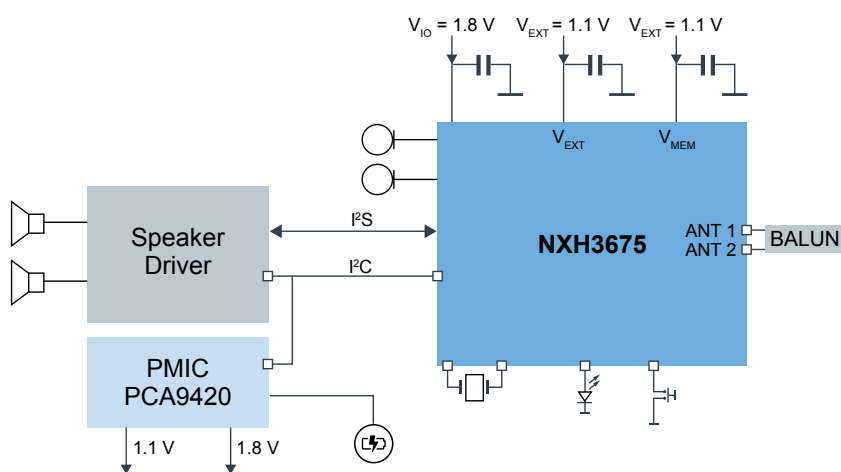

## EVALUATION KIT - HEADSET



[nxp.com/NXH3675](https://www.nxp.com/NXH3675)

NXP and the NXP logo are trademarks of NXP B.V. Cortex is a trademark or registered trademark of Arm Limited (or its subsidiaries) in the US and/or elsewhere. The related technology may be protected by any or all of patents, copyrights, designs and trade secrets. The Bluetooth® word mark and logos are registered trademarks owned by Bluetooth SIG, Inc. and any use of such marks by NXP Semiconductors is under license. All other product or service names are the property of their respective owners. © 2022 NXP B.V.

Document Number: NXH3675A4FS REV 2